

RICAMBI - SPARE PARTS - ERSATZTEILE

LAVABICCHIERI

GLASSWASHERS

LAVE VERRES

GLÄSERSPÜLMASCHINE

MASTER 35 - MASTER 35PS

MASTER 40 - MASTER 40PS



LAVASTOVIGLIE - DISHWASHERS - LAVE VAISSELLE - GLÄSERSPÜLMASCHINE

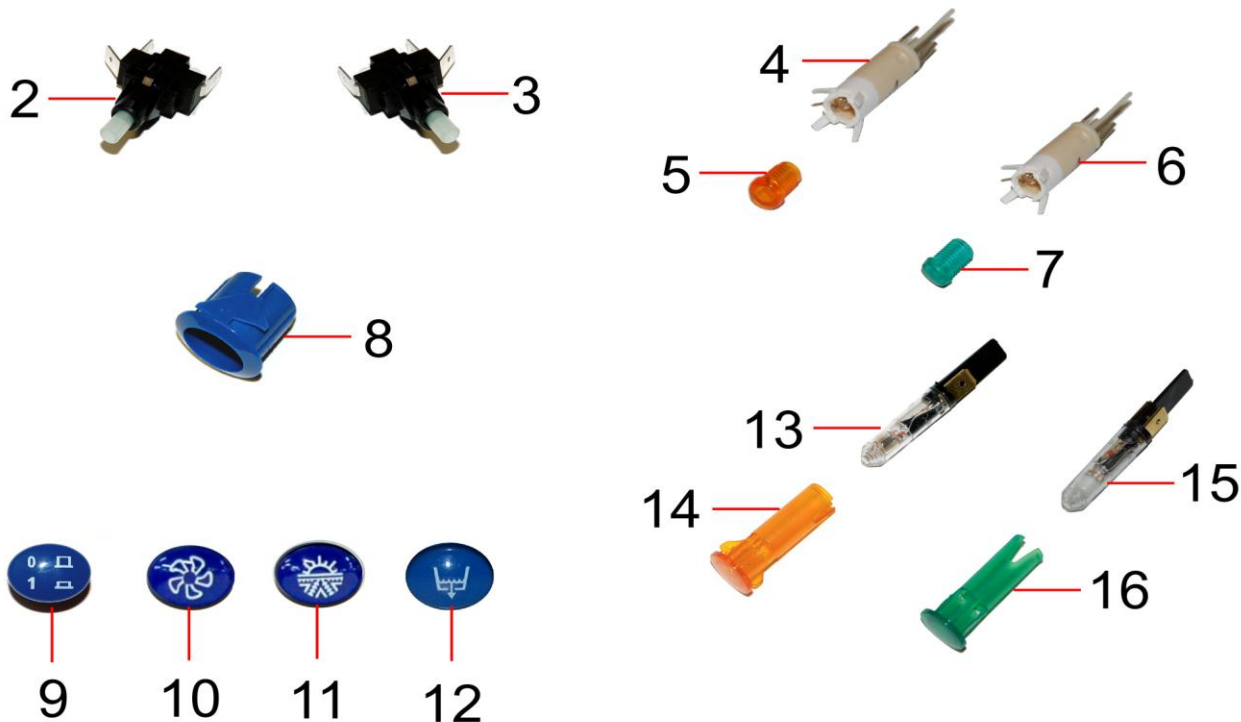

Pos.	Codice	Descrizione	Description	Description
1	GMPS1CSN08	Pannello superiore master 35	Top panel master 35	Panneau supérieur master 35
1A	GMPS1CSNPS09	Pannello superiore master 35PS	Top panel master 35PS	Panneau supérieur master 35PS
2	CEDPU08	Deviatore push CM (2008)	Inner switch body, momentary,CM(2008)	Deviateur CM (2008)
3	CEPUD08	Pulsante push CM (2008)	Inner switch body, latched, CM (2008)	Bouton CM (2008)
4	CESPA6	Lampada arancio 6mm	Lamp assy, 6mm, orange	Ampoule orange, 6mm
5	CEGA6	Gemma arancio 6mm	Lens, orange, 6mm	Voyant orange, 6mm
6	CESPV6	Lampada verde 6mm	Lamp assy, 6mm, green	Ampoule verte, 6mm
7	CEGV6	Gemma verde 6mm	Lens, green, 6mm	Voyant vert, 6mm
8	CETPD16BL	Supporto tasto ellittico blu	Holder for switch body, blue (2008)	Support bouton elliptique blue
9	CETPED16BL01	Tasto ellittico blu "0-1"	Switch function insert, 1-0, blue	Bouton elliptique blue "0-1"
10	CETPED16BLPC	Tasto ellittico blu "Partenza ciclo"	Switch function insert, cycle, blue	Bouton elliptique blue depart cycle
11	CETPED16BLRF	Tasto ellittico blu "Risciacquo freddo"	Switch function insert, cold rinse, blue	Bouton elliptique blue rinçage froid
12	CETPED16BLPS	Tasto ellittico blu "pompa scarico"	Switch function insert,drain pump, blue	Bouton elliptique blue pompe de vidange
13	CESP27	Spia arancio	Warning light, orange	Ampoule voyant, orange
14	CESPE32	Gemma arancio	Cover, orange	Voyant orange
15	CESP27V	Spia verde	Warning light, green	Ampoule voyant, vert
16	CESPE31	Gemma verde	Cover, green	Voyant vert

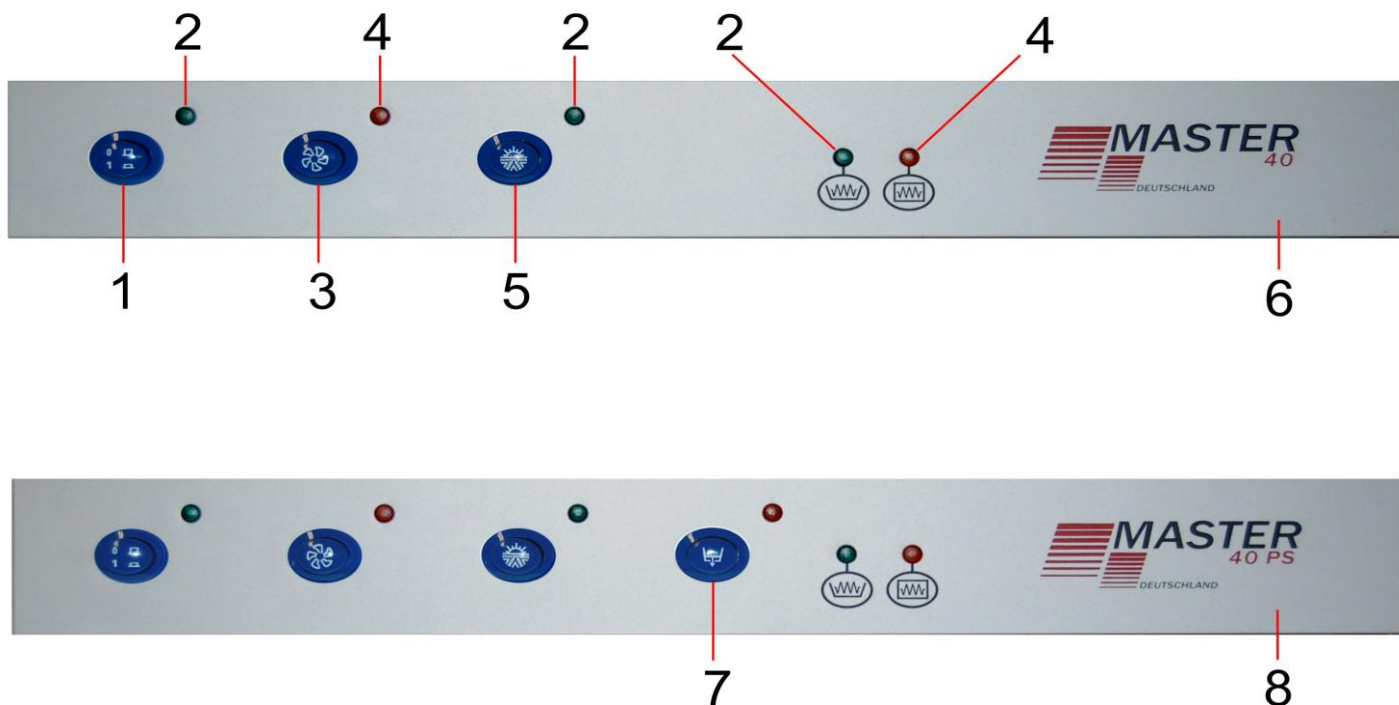

Pos.	Codice	Descrizione	Description	Description
1	CETPED16BL01	Tasto ellittico blu "0-1"	Switch function insert, 1-0, blue	Bouton elliptique blue "0-1"
2	CEGV6	Gemma verde, 6mm	Lens, green, 6mm	Voyant vert, 6mm
3	CETPED16BLPC	Tasto partenza ciclo ellittico blu	Switch function insert, cycle, blue	Bouton elliptique blue depart cicle
4	CEGA6	Gemma arancio dm. 6mm	Lens, orange, 6mm	Voyant orange, 6mm
5	CETPED16BLRF	Tasto risciacquo freddo ellittico blu	Switch function insert, cold rinse, blue	Bouton elliptique blue rinçage froid
6	CETSMMASTER40	Targhetta serigrafata master 40	Printed label "Master 40"	Plaquette sérigraphiée "Master 40"
7	CETPED16BLPS	Tasto pompa scarico ellittico blu	Switch function insert, drain, blue	Bouton elliptique blue pompe de vidange
8	CETSMMASTER40PS	Targhetta serigrafata master 40PS	Printed label "Master 40PS"	Plaquette sérigraphiée "Master 40PS"

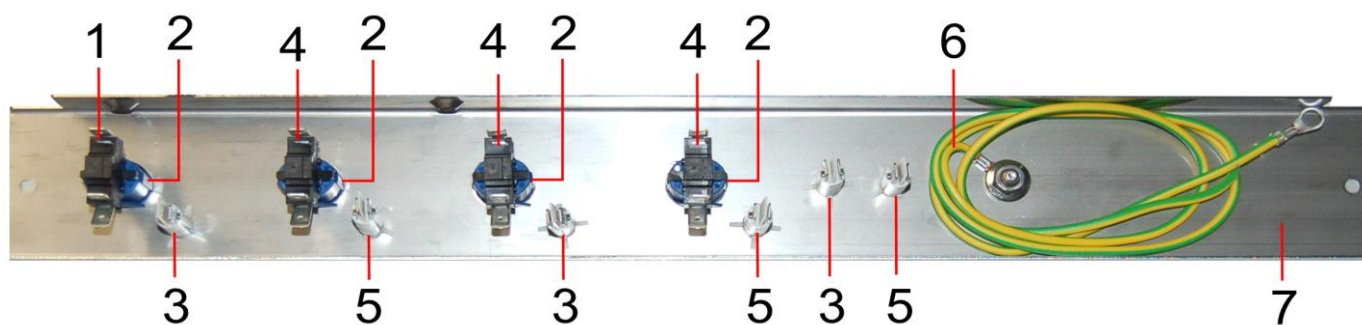

Pos.	Codice	Descrizione	Description	Description
1	CEDPU08	Deviatore push CM (2008)	Inner switch body, momentary, CM (2008)	Deviateur CM (2008)
2	CETPD16BL	Supporto tasto ellittico blu	Holder for switch body, blue (2008)	Support bouton elliptique blue
3	CESPV6	Lampada verde, 6mm	Lamp assy, 6mm, green	Ampoule vert, 6mm
4	CEPUD08	Pulsante push unipolare cm (2008)	Inner switch body, latched, CM(2008)	Bouton CM (2008)
5	CESPA6	Lampada arancio, 6mm	Lamp assy, 6mm, orange	Ampoule orange, 6mm
6	CECBCTB2	Catenaria circuito terra	Earth grounding wire	Cable de circuit à la terre
7	GMPI2D16STD	Portainterruttori inox	Steel control panel	Porte-interrupteur inox

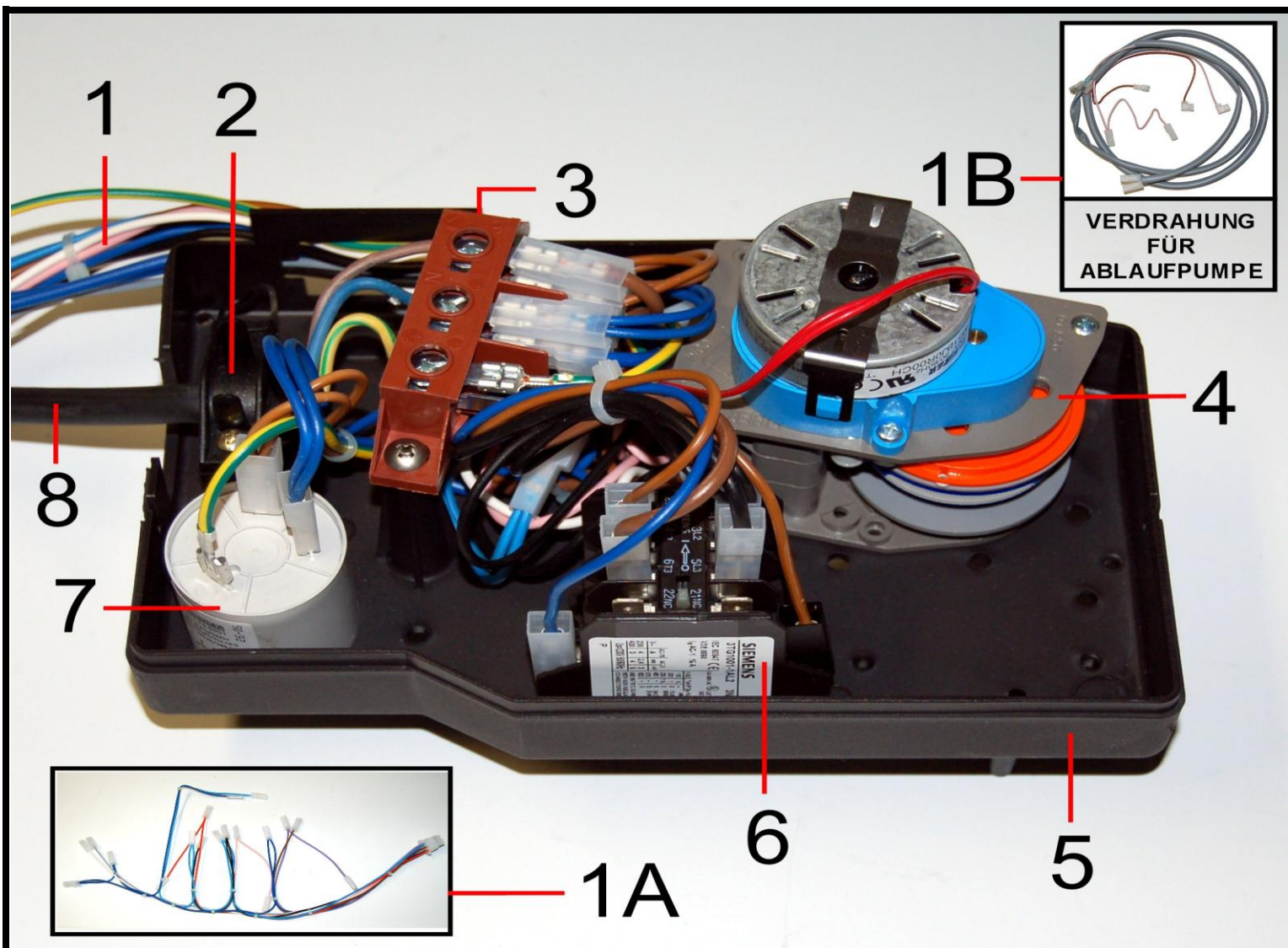

Pos.	Codice	Descrizione	Description	Description
1	CECBJ09	Cablaggio	Lower loom	Cable de connexion
1A	CECBSPCCS	Cablaggio superiore	Upper loom	Cablage supérieur
1B	CECBPS12CS	Cablaggio pompa scarico	Drain pump wiring loom	Cablage pompe de vidange
2	CEFI6	Fissacavo interno con viti	Cable clamp	Arrêt de câble intérieur
3	CEM0S	Morsettiera	3-way terminal block	Bornier
4	GETF12	Timer ciclo	Cycle timer, 2.1/2 mins, type B	Timer cycle
5	CEPCEBCSL	Base scatola cablaggio	Electric component box body	Boîte cablage
6	CECTF	Teleruttore	4-p contactor	Contacteur
7	CEFA	Filtro antidisturbo	Suppressor	Filtre électrique
8	CECE25	Cavo alimentazione	Electric supply cable	Cable d'alimentation
9	CEPCECCSL	Coperchio scatola cablaggio	Electric component box lid	Couvercle boîte cablage
10	CECBJ09CC	Scatola cablaggio completa assemblata	Electrical component assembly	Boîte cablage

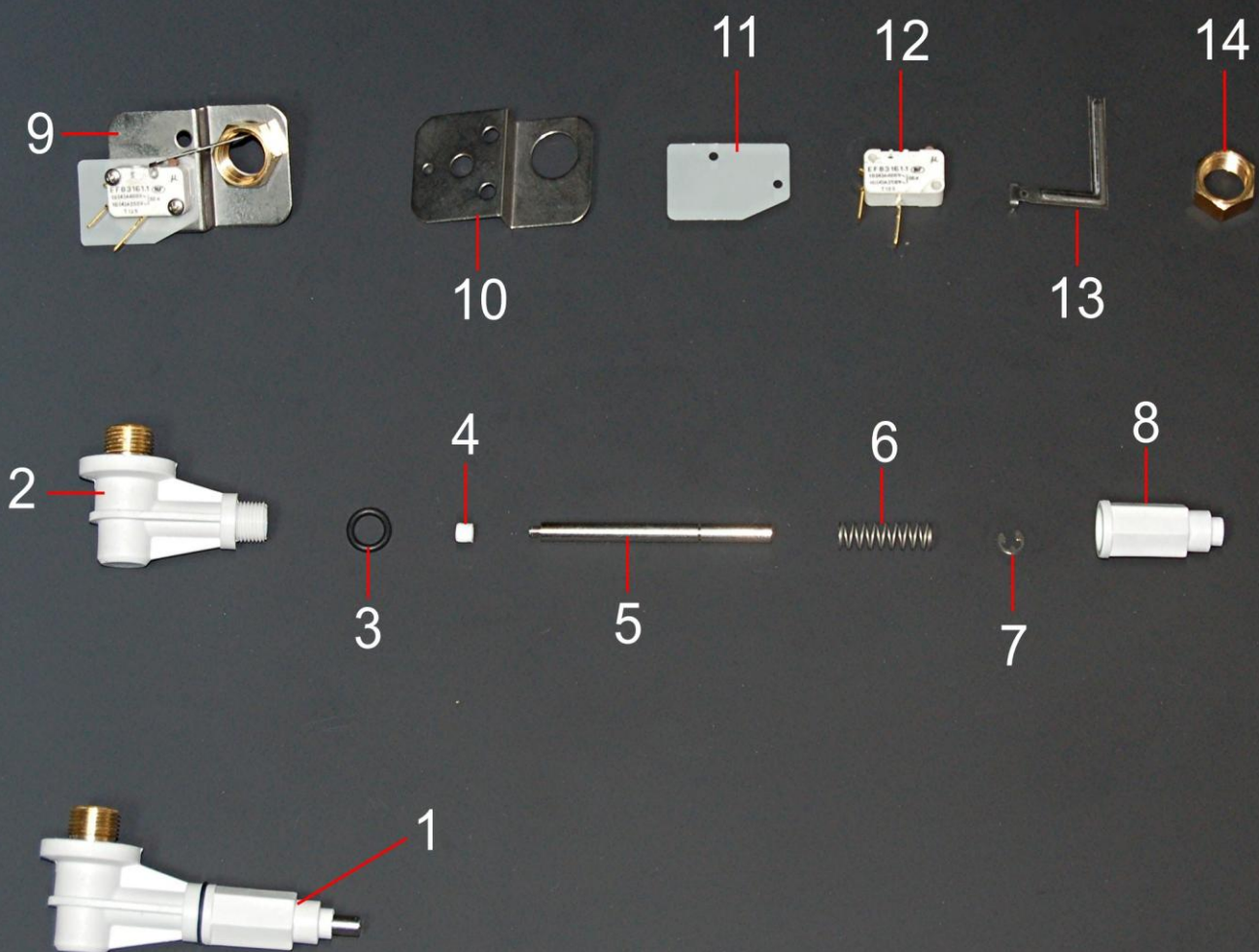

Pos.	Codice	Descrizione	Description	Description
1	CEMP1823B	Sicurezza porta completa	Door plunger assembly	Securité de porte assemblée
2	CEMP18B	Corpo posteriore sicurezza porta	Door plunger elbow	Corps postérieur
3	OR4036	Or sicurezza porta	O ring 4036	Joint OR 4036
4	CEMPPIB	Puntale isolante astina sicurezza porta	Push rod end cap	Poussoir plastique
5	CEMP21	Astina sicurezza porta	Push rod	Tige securité porte
6	CEMP20	Molla sicurezza porta	Door plunger spring	Ressort securité porte
7	CEMP22	Seeger astina sicurezza porta	Circlip	Circlips
8	CEMP23B	Corpo anteriore sicurezza porta	Door plunger body	Corps antérieur
9	CEMP12CSC	Microinterruttore standard completo	Door switch assy complete	Micro contact porte complet
10	CEMP13CS	Squadretta micro porta standard	Bracket for door switch	Support interrupteur
11	CEISOMPNT	Isolante micro porta	Insulating plate	Isolant
12	CEMP12SM	Microinterruttore	Door micro switch only	Interrupteur
13	CEMP12ACS	Leva microinterruttore standard	Operating arm, right angled	Levier micro-interrupteur
14	D038A	Dado ottone 3/8"	Brass lock nut 3/8"	Ecrou 3/8"

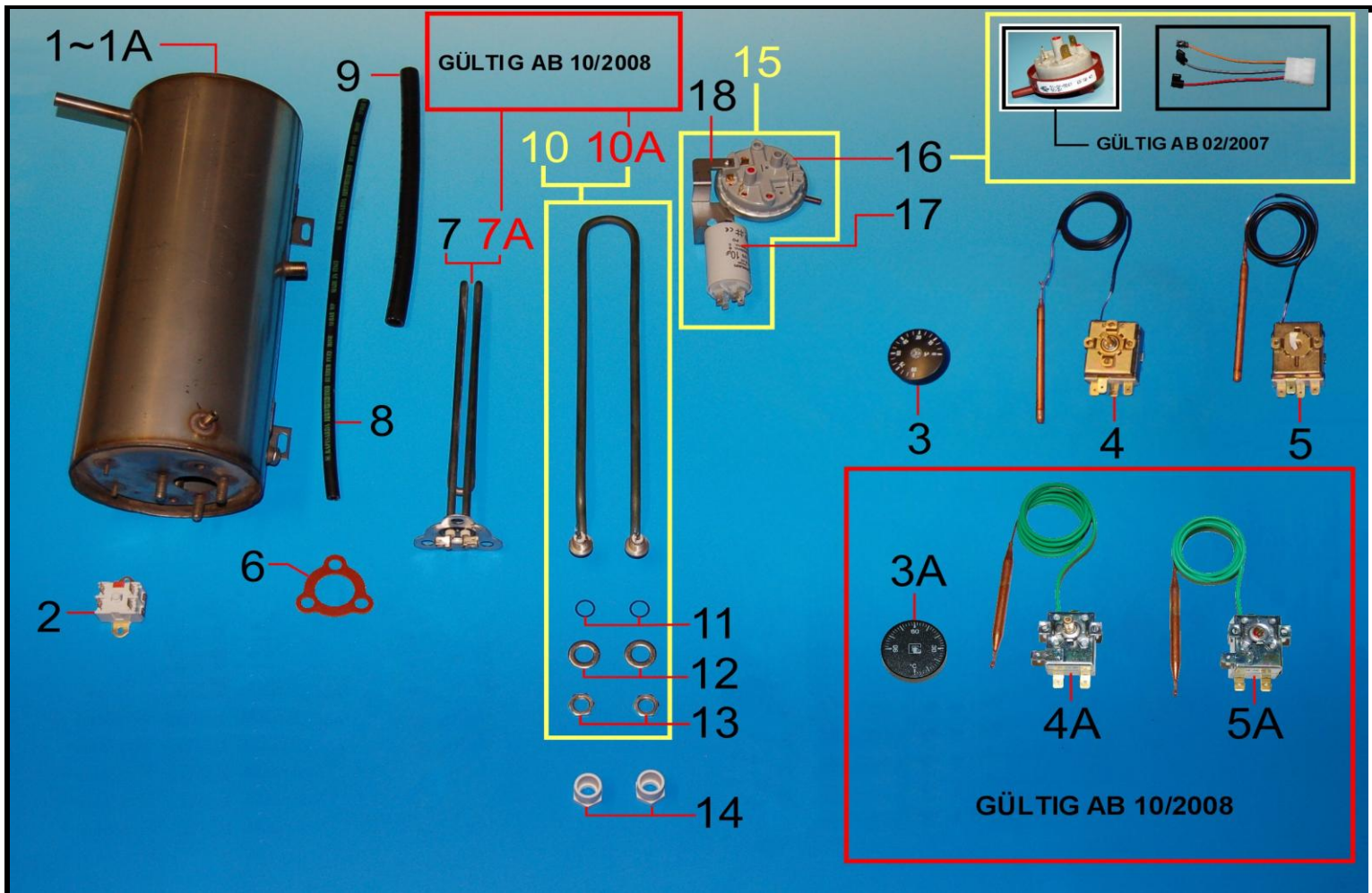

Pos.	Codice	Descrizione	Description	Description
1	GB11NT	Boiler 35	Boiler 35	Surchauffeur 35
1A	GB21NT	Boiler 40	Boiler 40	Surchauffeur 40
2	CESB454	Termostato sicurezza boiler	Boiler safety thermal switch	Termostat sécurité surchauffeur
3	CEMTB	Manopola termostato	Knob, thermostat	Manette thermostat
3A	CEMTBCAM	Manopola termostato (2008)	Knob, thermostat (2008)	Manette thermostat (2008)
4	CETB85	Termostato boiler regolabile	Adjustable control thermostat	Termostat surchauffeur réglable
4A	CETB85CAM	Termostato boiler regolabile (2008)	Adjustable control thermostat (2008)	Termostat surchauffeur réglable (2008)
5	CETV55	Termostato vasca fisso	Fixed wash control thermostat	Termostat cuve fix
5A	CETV55CAM	Termostato vasca fisso (2008)	Fixed wash control thermostat (2008)	Termostat cuve fix (2008)
6	G42303S	Guarnizione resistenza boiler	Rinse element seal, small	Joint torique résistance surchauffeur
7	CERB22	Resistenza boiler 2200 W	Rinse element, 2.2kW	Résistance surchauffeur 2200 W
7A	CERB2712	Resistenza boiler 2700 W	Rinse element, 2.7kW	Résistance surchauffeur 2700 W
8	TG510DS	Tubo gomma 5x10	R-aid tube to boiler	Tuyau caoutchouc 5x10
9	TG1117	Tubo gomma 11x17	Standard rinse hose 11mm bore	Tuyau caoutchouc 11x17
10	CERV8	Resistenza vasca 800 w	Wash element, 0.8kW	Résistance de cuve 0,8 Kw
10A	CERV18	Resistenza vasca 1800 w	Wash element, 1.8kW	Résistance de cuve 1,8 Kw
11	ORRV	Or resistenza vasca	O rings for wash element	Joint torique résistance cuve
12	VRP12I	Rondella piana Ø 12	Washer	Rondelle, diam 12mm
13	VDRV	Dado resistenza vasca	Lock nut	Ecrou fixation résistance cuve
14	CEPRV0	Protezione resistenza vasca	Protection, wash element	Protection résistance cuve
15	AMOSQPCCS1C	Squadretta assemblata condensatore pressostato	Assembly, pressure switch and capacitor	Support résistance condensateur
16	CEPR	Pressostato	Air pressure switch	Pressostat
17	CECN10	Condensatore	Capacitor 10 mi-F	Condensateur
18	AMOSQPCCS	Squadretta inox	Bracket	Support inox

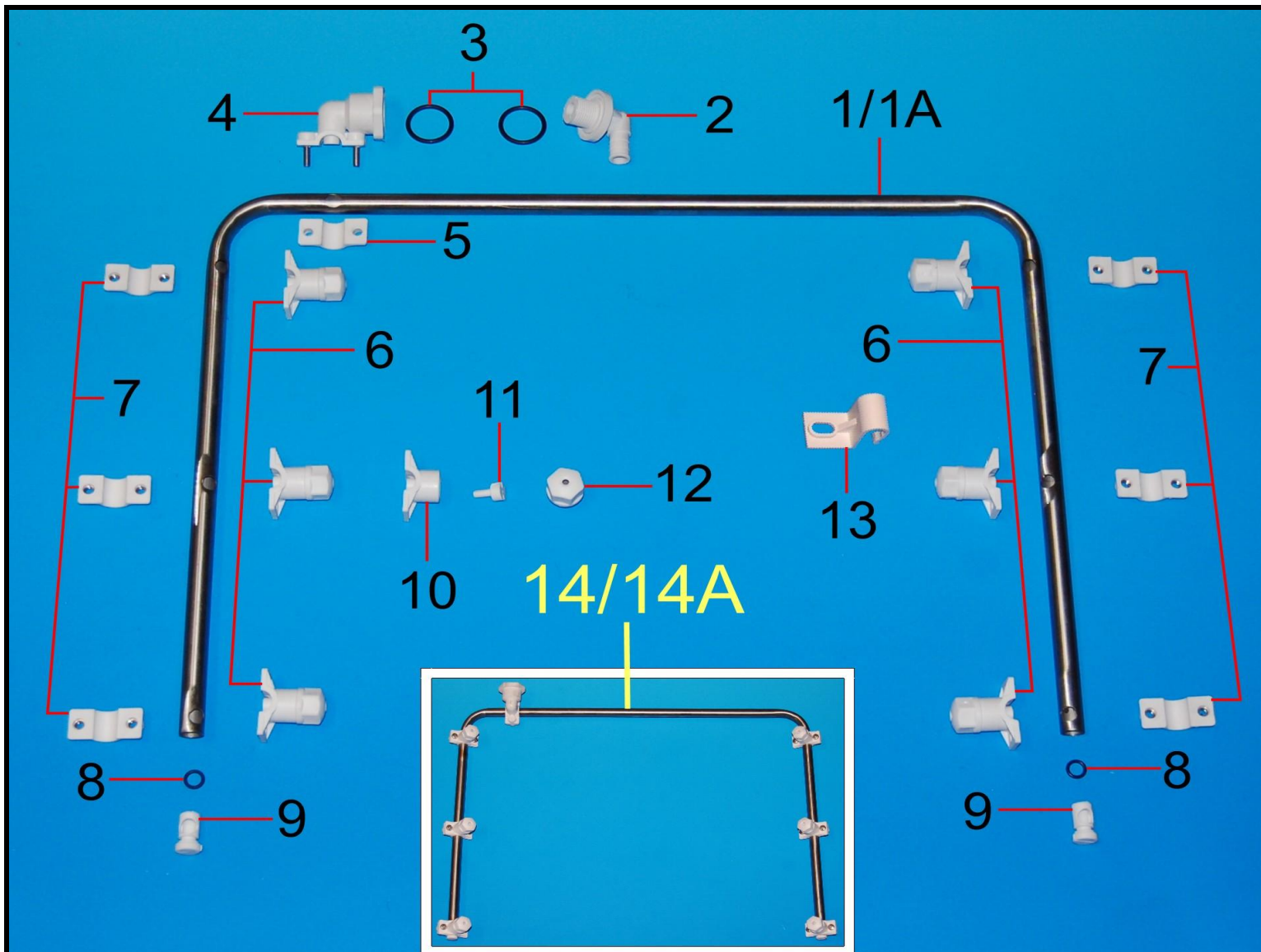

Pos.	Codice	Descrizione	Description	Description
1	GRS1Q	Asta inox mod. 35	Steel tube for top rinse, mod. 35	Rampe inox, mod. 35
1A	GRS2Q	Asta inox mod. 40	Steel tube for top rinse, mod. 40	Rampe inox, mod. 40
2	GRS06B	Raccordo fissaggio asta esterno	External rinse connection clamp	Raccord fixation rampe de rinçage extérieure
3	OR128	Or 128	O ring 128	Joint support
4	GRS03B	Raccordo asta interno	External rinse connection clamp	Raccord fixation rampe de rinçage intérieure
5	GRS04B	Cavallotto fissaggio asta	Rinse tube clamp	Support supérieur fixation rampe
6	GR019BBCOMP	Portagetto risciacquo assemblato	Rinse jet clamp assy	Support gicleur
7	GR019DB	Supporto inferiore portagetto	Rinse jet rear clamp	Support inférieur gicleur
8	OR106	Or 106	O ring door handle screw	Joint torique pour poignée
9	GR019GB	Tappo asta	Rinse arm plug	Bouchon rampe inox
10	GR019BB	Portagetto risciacquo	Rinse jet base	Support supérieur gicleur rinçage
11	GR021B	Diffusore risciacquo	Rinse jet spinner	Diffuseur de rinçage
12	GR020B	Getto risciacquo	Rinse jet	Gicleur de rinçage
13	GRS05B	Gancio fissaggio asta	Securing clamp	Crochet de support rampe
14	GRS1QBCM	Asta risciacquo assemblata, mod. 35	Fixed rinse arm complete, mod. 35	Rampe de rinçage complète, mod.35
14A	GRS2QBCM	Asta risciacquo assemblata, mod. 40	Fixed rinse arm complete, mod. 40	Rampe de rinçage complète, mod. 40

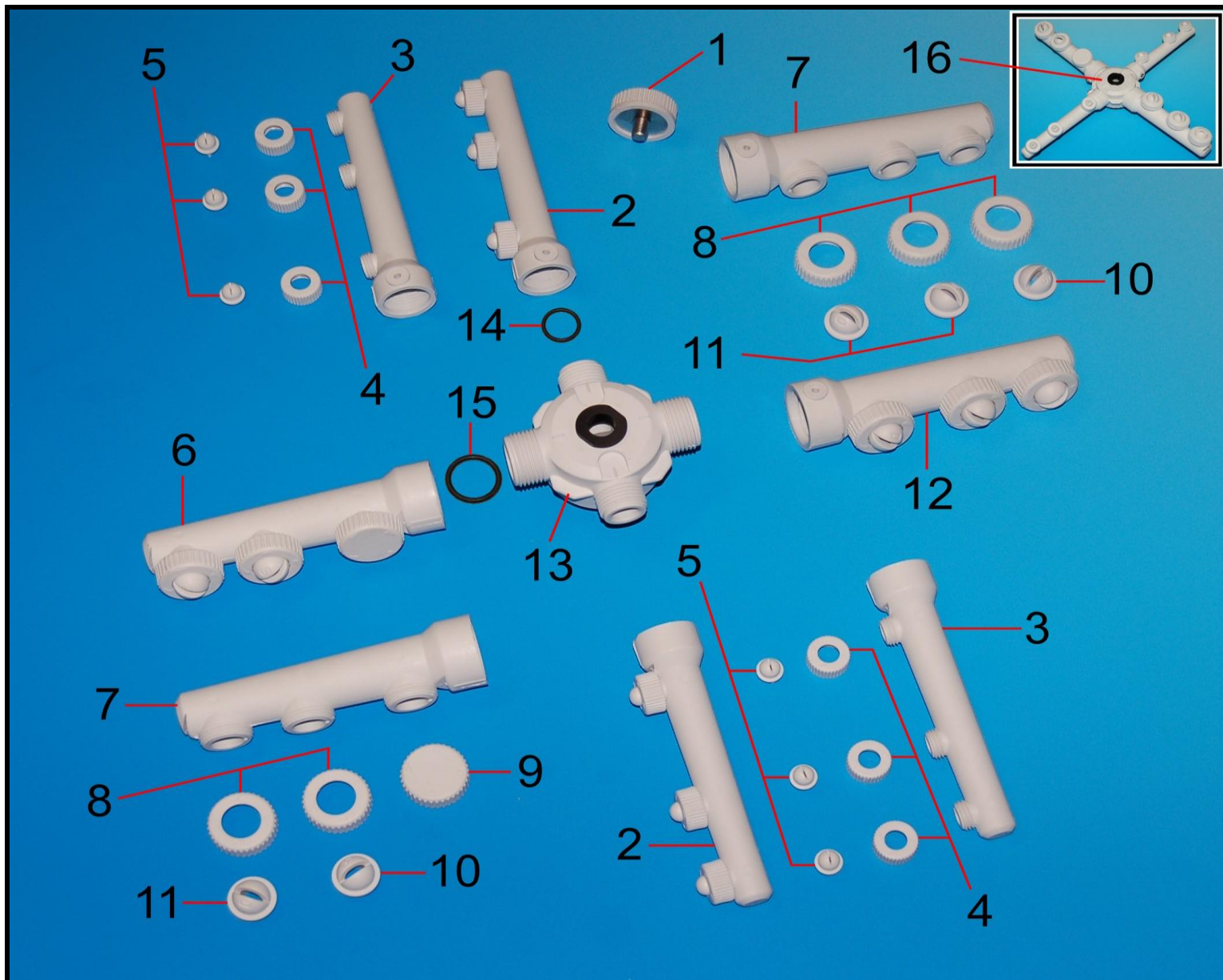

Pos.	Codice	Descrizione	Description	Description
1	LS09PB	Nottolino fissaggio girante	Spindle retaining nut	Ecrou pour pivot
2	LSI16CDSB	Asta risciacquo sinistra/destra assemblata	LH rinse arm complete	Rampe rinçage gauche/droite complèt
3	LSI16CB	Asta risciacquo	Rinse arm only	Rampe rinçage
4	LSI021B	Ghiera fissaggio getto risciacquo	Locating nut for rinse jets	Ecrou fixation gicleur rinçage
5	LSI020B	Getto risciacquo	Rinse jet	Gicleur rinçage
6	LSI16BSB	Asta lavaggio sinistra assemblata	LH wash arm, complete	Rampe lavage gauche avec gicleurs
7	LSI16BB	Asta lavaggio	Wash arm only	Rampe lavage
8	LSI017B	Ghiera fissaggio getto lavaggio	Locating nut for wash jets	Ecrou serrage gicleur lavage
9	LSI018B	Tappo getto lavaggio	Wash arm blank	Bouchon gicleur de lavage
10	LSI016B	Getto lavaggio sinistro stretto	Wash jet, LH, marked "s"	Gicleur lavage gauche
11	LSI015B	Getto lavaggio destro stretto	Wash jet, RH marked "d"	Gicleur lavage droite
12	LSI16BDB	Asta lavaggio destra assemblata	RH wash arm complete	Rampe lavage droite avec gicleurs
13	LSI0607AB	Mozzo girante	Centre boss c/w bushes	Moyeu central avec bagues
14	OR118	Or 118	O ring 118	Joint torique rampe rinçage
15	OR124	Or 124	O ring 124	Joint torique rampe lavage
16	LSI16BBB	Girante completa assemblata	Rotating wash assy complete	Tourniquet complet assemblé

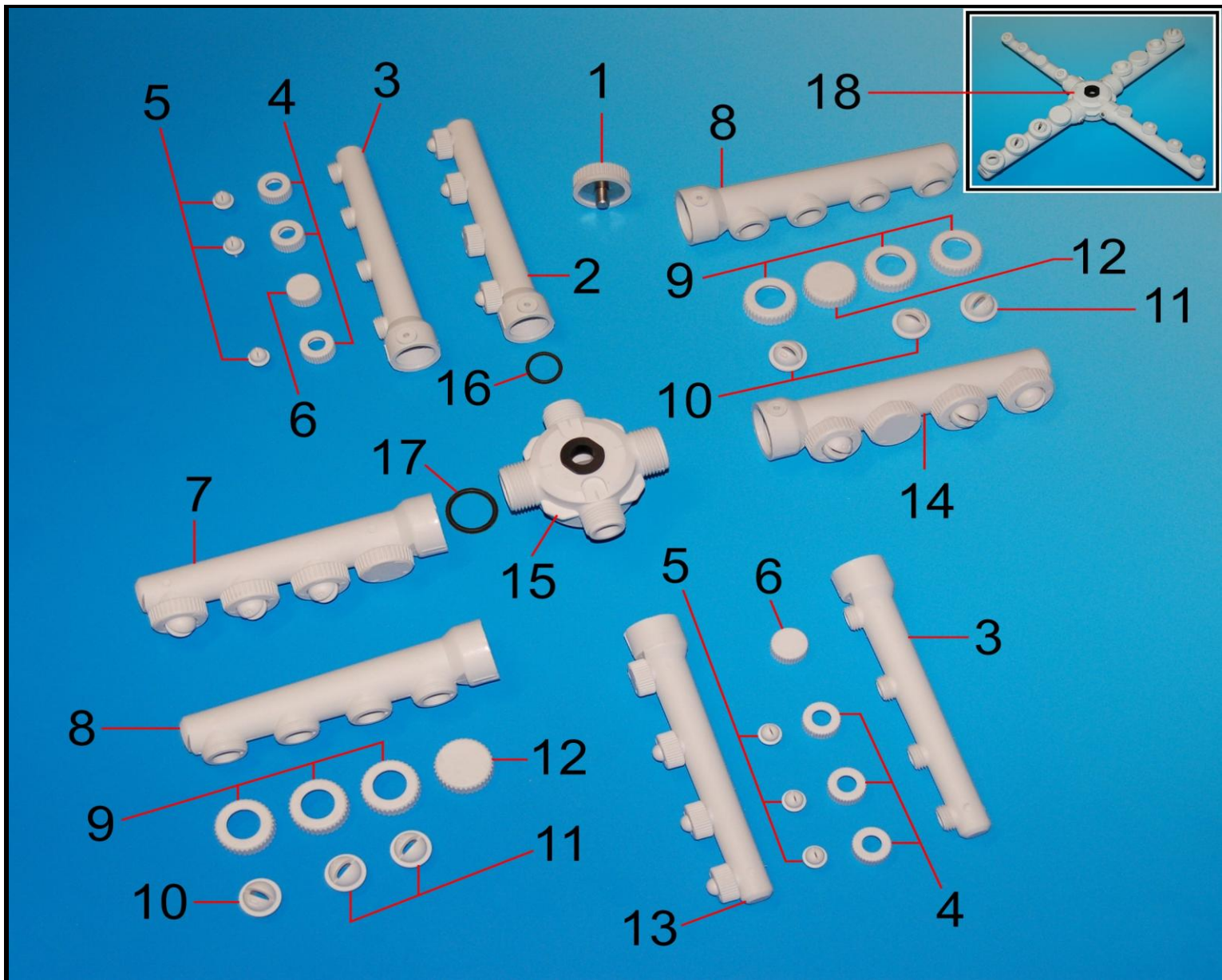

Pos.	Codice	Descrizione	Description	Description
1	LS09PB	Nottolino fissaggio girante	Spindle retaining nut	Ecrou pour pivot
2	LSI26CSB	Asta risciacquo sinistra assemblata congetti	Rinse arm with jets, LH	Rampe rinçage gauche, avec gicleur
3	LSI26CB	Asta risciacquo	Rinse arm only	Rampe rinçage
4	LSI021B	Ghiera fissaggio getto risciacquo	Locating nut for rinse jets	Ecrou fixation gicleur rinçage
5	LSI020B	Getto risciacquo	Rinse jet	Gicleur rinçage
6	LSI022B	Tappo getto risciacquo	Blank for rinse arm	Bouchon
7	LSI26BSB	Asta lavaggio sinistra assemblata con getti	LH wash arm complete	Rampe lavage gauche, avec gicleur
8	LSI26BB	Asta lavaggio	Wash arm only	Rampe lavage
9	LSI017B	Ghiera fissaggio getto lavaggio	Locating nut for wash jets	Ecrou fixation gicleur lavage
10	LSI015B	Getto lavaggio destro stretto	Wash jet, RH marked "D"	Gicleur lavage droite
11	LSI016B	Getto lavaggio sinistro stretto	Wash jet, LH, marked "D"	Gicleur lavage gauche
12	LSI018B	Tappo getto lavaggio	Wash arm blank	Bouchon
13	LSI26CDB	Asta risciacquo destra assemblata	RH rinse arm complete	Rampe rinçage droite complète
14	LSI26BDB	Asta lavaggio destra assemblata	RH wash arm complete	Rampe lavage droite complète
15	LSI0607AB	Mozzo girante	Centre boss c/w bushes	Moyeu central avec bagues
16	OR118	Or 118	O ring 118	Joint torique rampe rinçage
17	OR124	Or 124	O ring 124	Joint torique rampe lavage
18	LSI26BBB	Girante completa assemblata	Rotating wash assy complete	Tourniquet complet assemblé

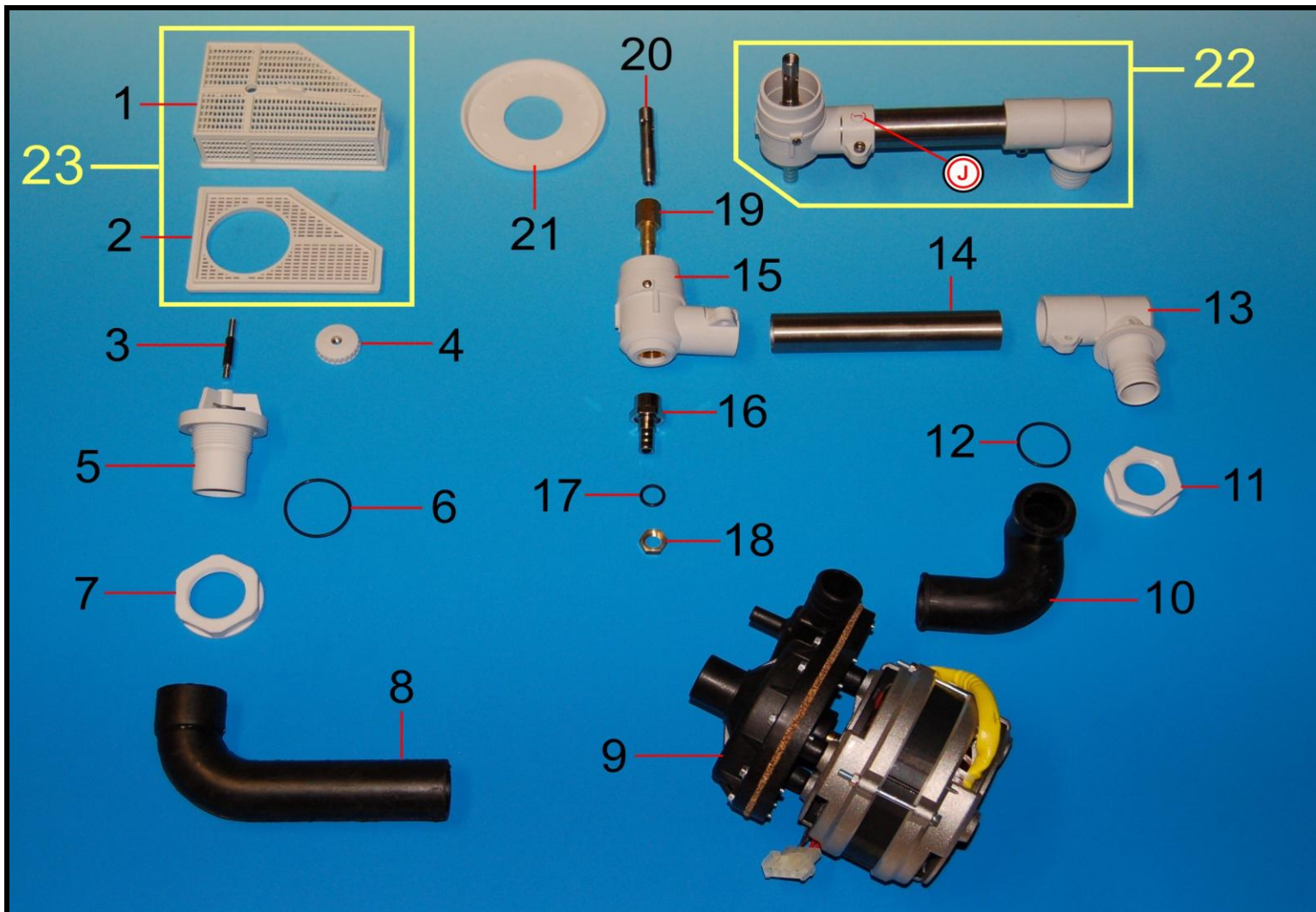

Pos.	Codice	Descrizione	Description	Description
1	GA115RV0	Filtro aspirazione	Plastic filter upper body	Filtere d'aspirazione
2	GA115RAV0	Piastra filtro aspirazione	Plastic filter base	Plaqué inférieure filtre
3	GAGS1299	Astina filtro	Filter spindle	Tige de filtre
4	GA013B	Nottolino filtro	Filter retaining nut	Ecrou de filtre
5	GA111B	Piletta aspirazione	Drain filter boss	Bonde d'aspiration
6	OR3168	Or 3168	O-ring 3168	Joint 3168
7	DP114	Dado 1" ¼	Plastic nut 1"1/4	Ecrou plastique 1"1/4
8	GA18	Manicotto aspirazione	Inlet hose	Durite d'aspiration
9	EP30	Elettropompa	Wash pump complete, 0.3 HP	Pompe de lavage, 0,3 HP
10	GL1T22	Manicotto mandata	Outlet hose	Durite de refoulement
11	DP1	Dado 1"	Nut 1"	Ecrou plastique , 1"
12	OR3131	Or 3131	O-ring 3131	Joint torique pour colonne
13	LI126FCB	Piletta entrata lavaggio	Wash elbow and column	Bonde entrée complète
14	LI12830	Tubo inox interno	Wash extension tube	Tube inox
15	LI029CBB	Supporto inferiore	Bottom boss assy	Support inférieur complet
16	LI133FOT	Supporto risciacquo	Rinse support	Support rinçage
17	OR117	Or 117	O-ring 117	Joint torique pour bouchon
18	D014	Dado ¼"	Brass nut 1/4"	Ecrou 1/4"
19	LI130	Prolunga perno	Spindle extension	Extension pivot
20	LI18F	Perno inox	Stainless steel upper spindle	Pivot inox rinçage
21	LI034PV0	Piattello inferiore	Deflector disk	Défecteur
22	GLICQ1JBCOMP	Gruppo inferiore completo assemblato	Lower elbow and boss assy complete	Groupe inférieur complet
23	GA115RCBV0	Filtro aspirazione completo	Plastic filter, complete	Filtere d'aspiration complet

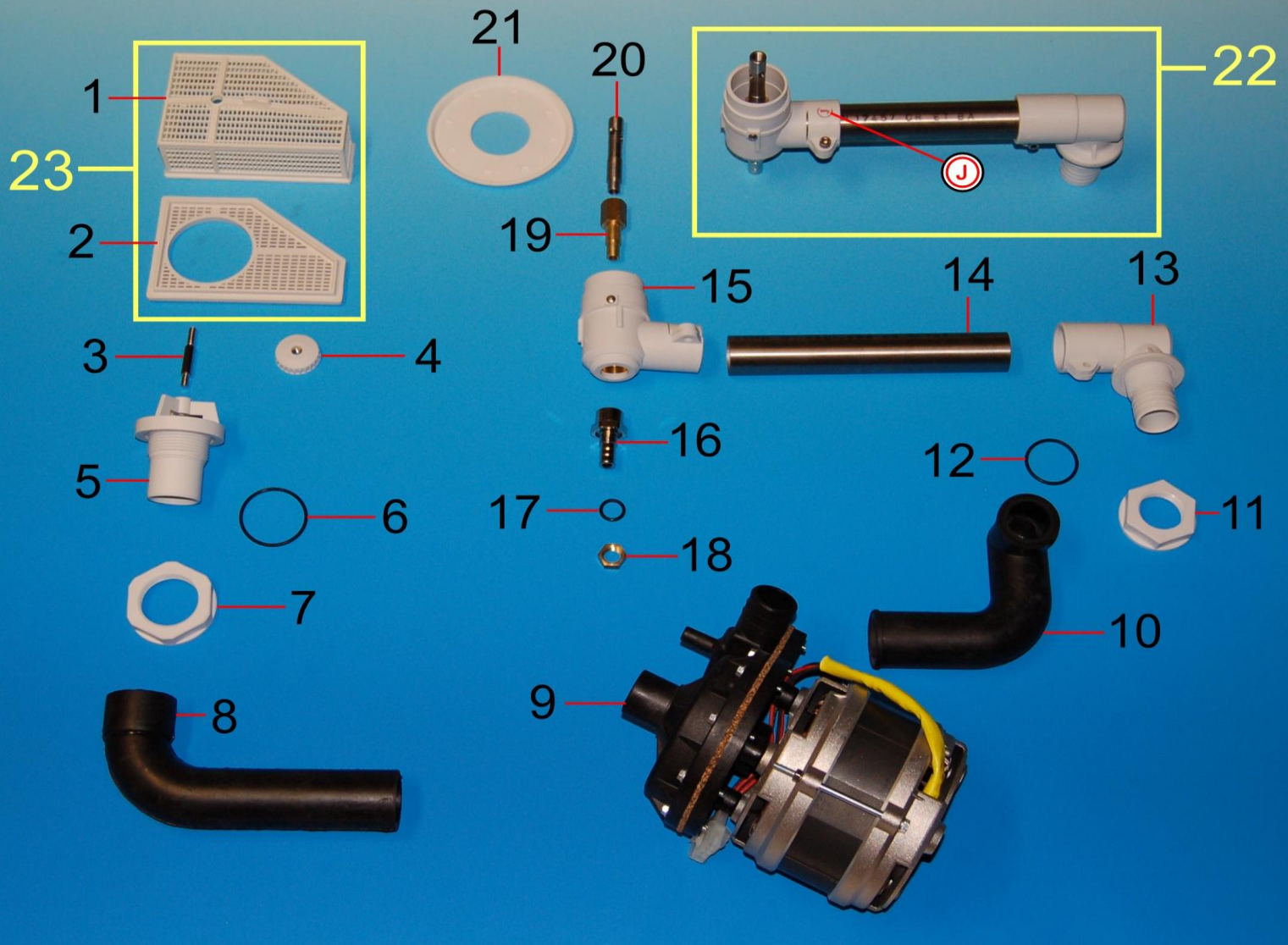

Pos.	Codice	Descrizione	Description	Description
1	GA115RV0	Filtro aspirazione	Plastic filter upper body	Filtre d'aspiration
2	GA115RAV0	Piastra filtro aspirazione	Plastic filter base	Plaque inférieur filtre
3	GAGS1299	Astina filtro	Filter spindle	Tige de filtre
4	GA013B	Nottolino filtro	Filter retaining nut	Ecrou de filtre
5	GA111B	Piletta aspirazione	Drain filter boss	Bonde d'aspiration
6	OR3168	Or 3168	O-ring 3168	Joint OR 3168
7	DP114	Dado 1" ¼	Plastic nut, 1"1/4	Ecrou plastique , 1"1/4
8	GA18	Manicotto aspirazione	Inlet hose	Durite d'aspiration
9	EP60	Elettropompa	Wash pump complete 0.6 HP	Pompe de lavage, 6,0 Hp
10	GL2T22	Manicotto mandata	Outlet hose	Durite de réfolement
11	DP1	Dado 1"	Nut 1"	Ecrou plastique
12	OR3131	Or 3131	O-ring 3131	Joint torique pour colonne
13	LI126FCB	Piletta entrata lavaggio	Wash elbow and column	Bonde entrée complète
14	LI22830	Tubo inox interno	Wash extension tube	Tuyau inox
15	LI029CBB	Supporto inferiore	Bottom boss assy	Support inférieur complet
16	LI133FOT	Supporto risciacquo	Rinse support	Support rinçage
17	OR117	Or 117	O ring 117	Joint torique pour bouchon
18	D014	Dado ¼"	Brass nut 1/4"	Ecrou 1/4"
19	LI130	Prolunga perno	Spindle extension	Extension pivot
20	LI18F	Perno inox corto	Stainless steel upper spindle	Pivot inox rinçage
21	LI034PV0	Piattello inferiore	Deflector disk	Défecteur
22	GLICQ2JBCOMP	Gruppo inferiore completo assemblato	Lower elbow and boss assy complete	Groupe inférieur complet
23	GA115RCBV0	Filtro aspirazione completo	Plastic filter, complete	Filtre d'aspiration complete

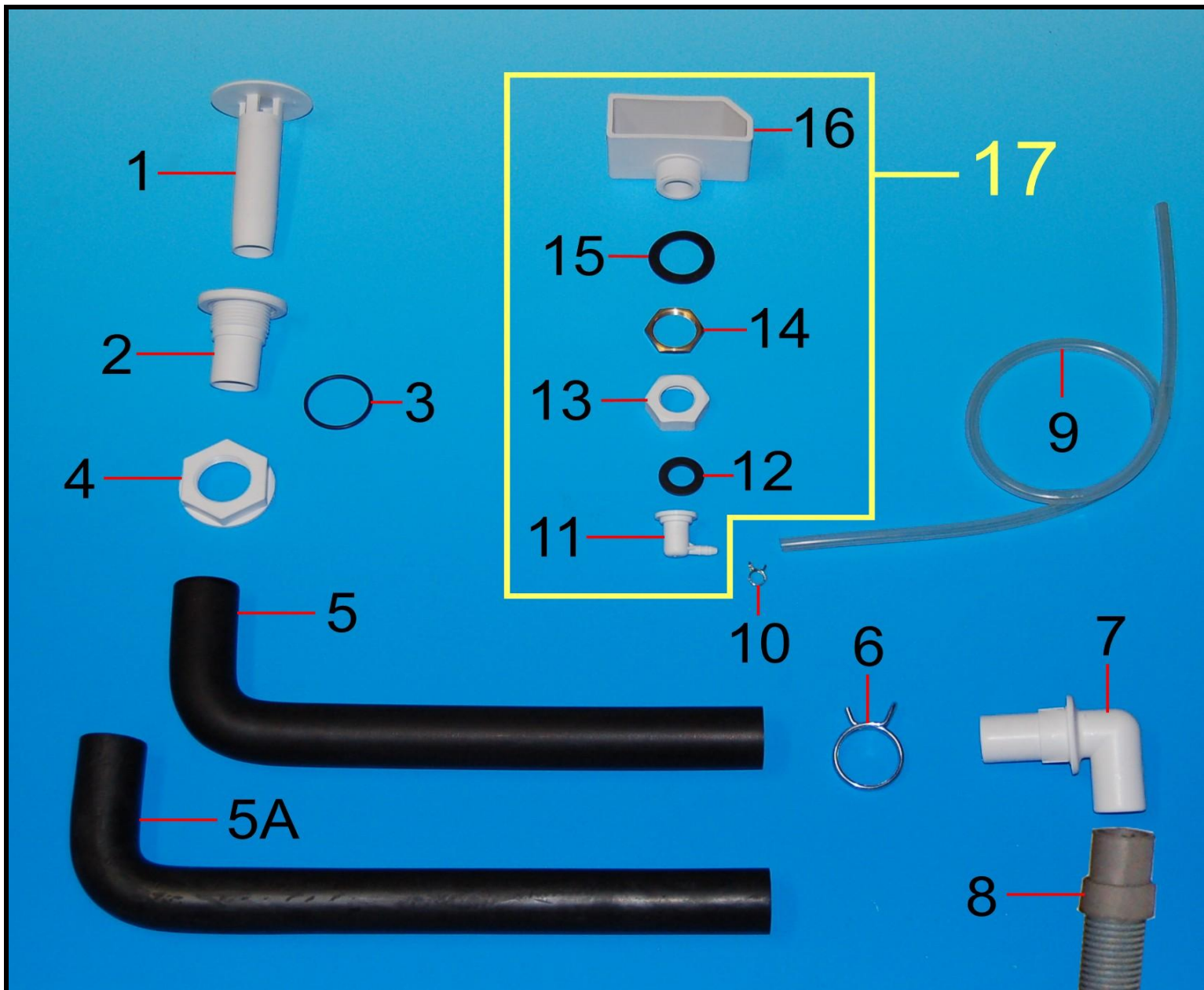

Pos.	Codice	Descrizione	Description	Description
1	GS116CCAB	Troppo pieno	Drain plug or standpipe	Bonde trop-plein, complet
2	GS117B	Piletta di scarico	Drain outlet boss	Bonde de vidange
3	OR3131	Or 3131	O-ring 3131	Joint torique pour colonne
4	DP1	Dado 1"	Nut 1"	Ecrou plastique
5	GS120	Manicotto di scarico mod. 35	Drain hose, mod. 35	Durite de vidange, mod. 35
5A	GS220	Manicotto di scarico mod. 40	Drain hose, mod. 40	Durite de vidange, mod. 40
6	FAM3040	Fascetta a molla	Hose clip 30-40	Collier élastique
7	GS121	Raccordo scarico 90°	Drain elbow 90°	Raccord de vidange à 90°
8	GS130	Tubo di scarico	Drain hose	Tube de vidange
9	TSIL48	Tubo silicone	Rinse-aid tube	Tube de vidange
10	FAM58	Fascetta a molla	Spring clip	Collier
11	GP026AB	Raccordo girevole	Air trap elbow	Raccord tournant
12	G251525G	Guarnizione raccordo girevole	Sealing washer	Joint raccord tournant
13	GP026BB	Dado raccordo girevole	Air tap elbow nut	Ecrou pour raccord tournant
14	D034	Dado 3/4"	Brass nut, 3/4"	Ecrou 3/4"
15	G382615G	Guarnizione trappola aria	Air trap seal	Joint
16	GP025B	Trappola aria	Air trap	Chambre de compression
17	GP025BCOMP	Trappola aria completa	Pressure vessel assy complete	Chambre de compression, complète

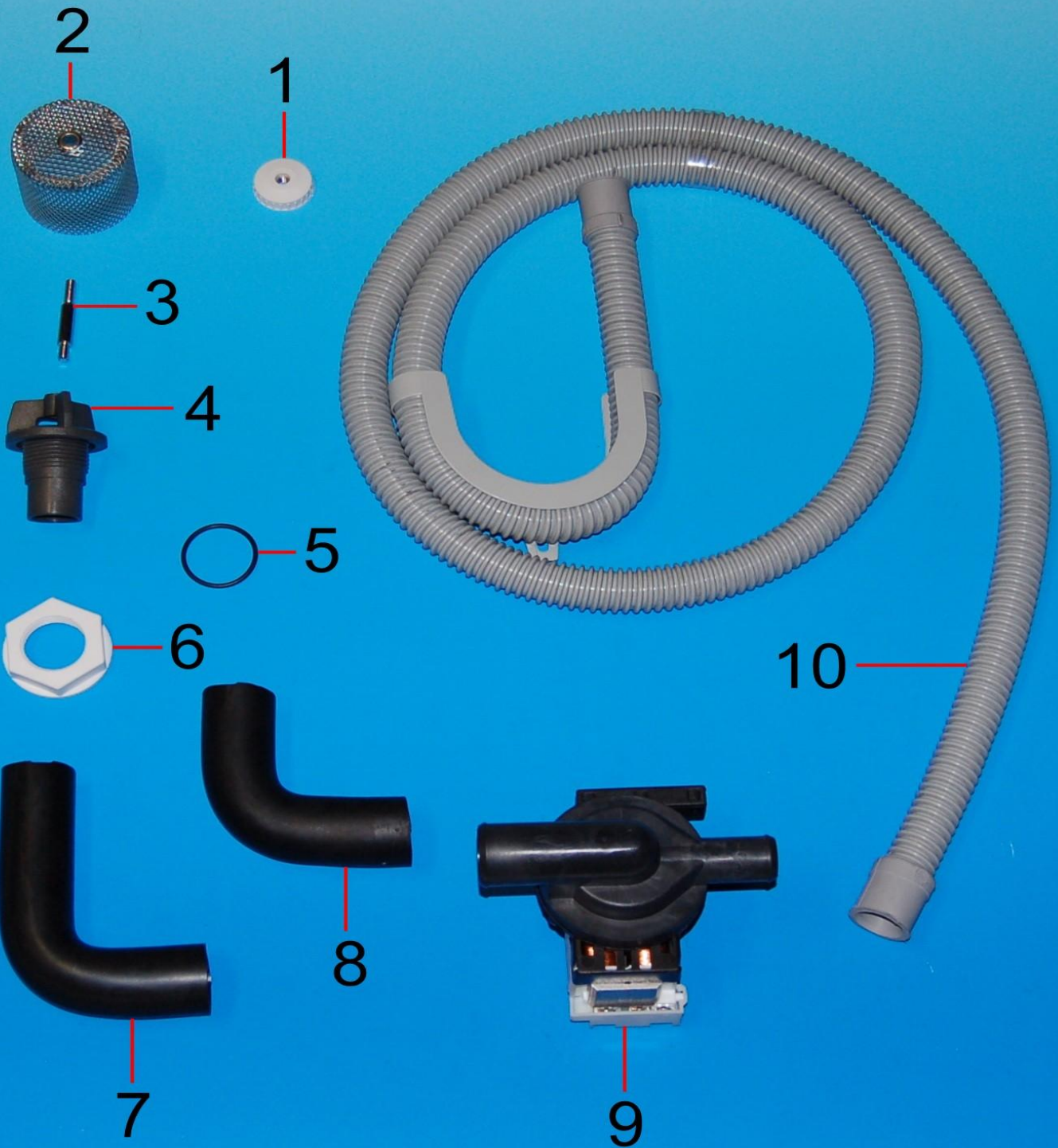

Pos.	Codice	Descrizione	Description	Description
1	GA013B	Nottolino filtro	Filter retaining nut	Ecrou de filtre
2	GAFAPS199	Filtro aspirazione pompa scarico	Drain pump Filter	Filtre pompe de vidange
3	GAGS1299	Astina filtro	Filter spindle	Tige de filtre
4	GAPS1299B	Piletta aspirazione pompa scarico	Drain boss	Bonde de vidange
5	OR3131	Or 3131	O-ring 3131	Joint torique pour colonne
6	DP1	Dado 1"	Nut 1"	Ecrou plastique
7	GS120SPEC1	Manicotto aspirazione, mod. 35PS	Inlet hose, mod. 35PS	Durite d'aspiration, mod. 35PS
8	GS120SPEC	Manicotto aspirazione, mod. 40PS	Inlet hose, mod. 40PS	Durite d'aspiration, mod. 40PS
9	CEPS5	Pompa scarico	Drain pump	Pompe de vidange
10	CEPS032	Tubo pompa scarico	Waste outlet hose (drain pump)	Tuyau de vidange

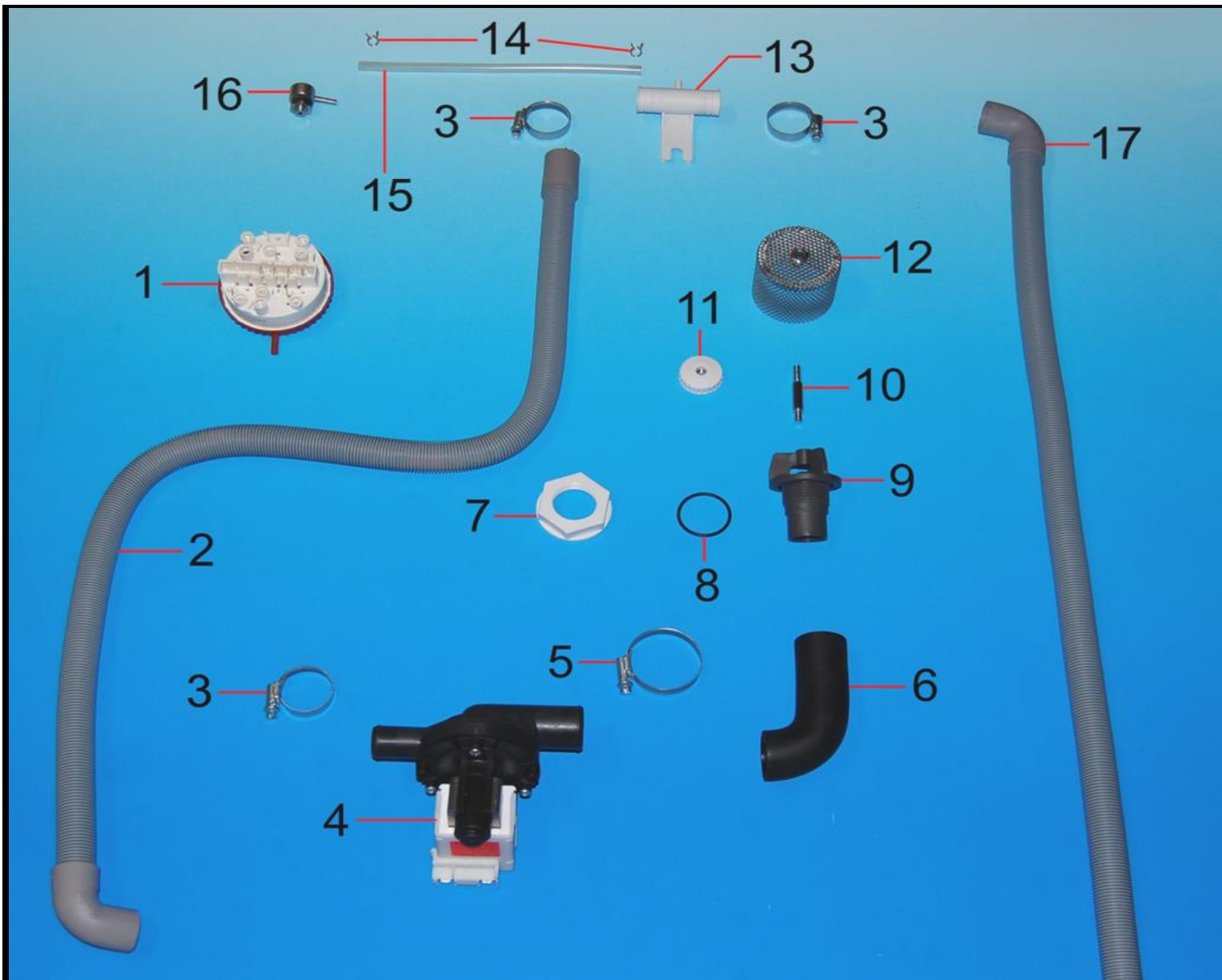

Pos.	Codice	Descrizione	Description	Description
1	CEPRE2LUL	Pressostato 2 livelli	Double air pressure switch	Pressostat 2 niveaux
2	GSTS820PS	Tubo scarico l.820 mm	Internal drain hose	Tuyau de vidange 1,820 mm
3	FA2532	Fascetta	Hose clip 25-32	Collier
4	CEPS5	Pompa scarico	Drain pump	Pompe de vidange
5	FA3040	Fascetta	Hose clip 30-40	Collier élastique
6	GS120SPEC1	Manicotto aspirazione	Inlet hose	Durite d'aspiration
7	DP1	Dado 1"	Nut 1"	Ecrou plastique
8	OR3131	Or 3131	O-ring 3131	Joint torique
9	GAPS1299B	Piletta aspirazione pompa scarico	Drain boss	Bonde d'aspiration pompe de vidange
10	GAGS1299	Astina filtro	Filter spindle	Tige de filtre
11	GA013B	Nottolino filtro	Filter retaining nut	Ecrou de filtre
12	GAFAPS199	Filtro aspirazione pompa scarico	Drain pump filter	Filtre pompe de vidange
13	CEPSVSF	Valvola non ritorno scarico	Drain non return valve	Valve non retour, vidange
14	FAM710	Fascetta a molla	Spring clip	Collier
15	TSIL48	Tubo silicone	Silicone tube	Tuyau silicone
16	GSDETPI10COMP	Portagomma inox completo	Conn'n elbow, steel, complete assy	Support inox complete
17	GSTS2500PS	Tubo scarico l.2500 mm	External drain outlet hose	Tuyau de vidange l,250 mm

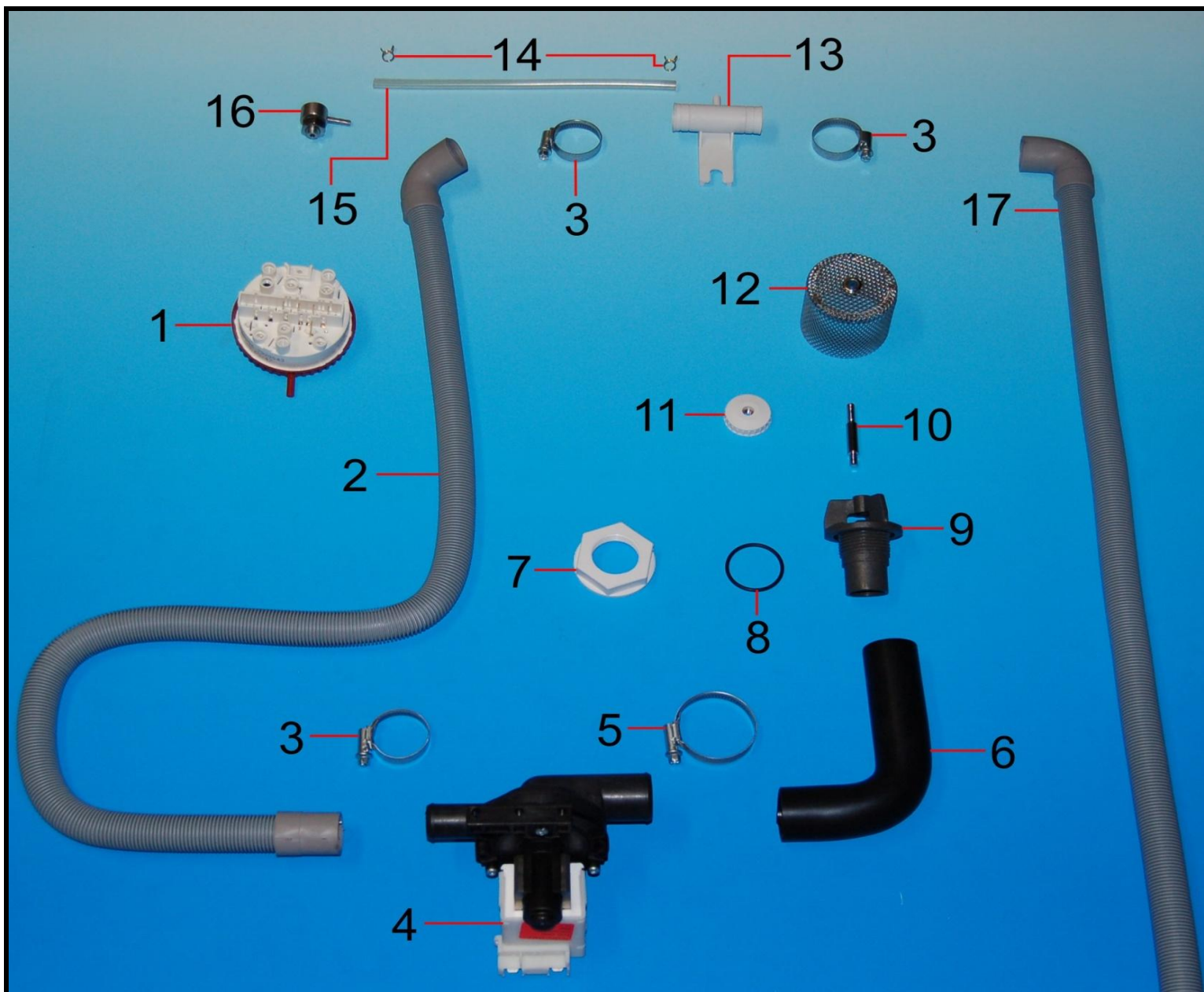

Pos.	Codice	Descrizione	Description	Description
1	CEPRE2LUL	Pressostato 2 livelli	Double air pressure switch	Pressostat 2 niveaux
2	GSTS820PS	Tubo scarico l.820 mm	Internal drain hose	Tuyau de vidange 1,820 mm
3	FA2532	Fascetta	Hose clip 25-32	Collier
4	CEPS5	Pompa scarico	Drain pump	Pompe de vidange
5	FA3040	Fascetta	Hose clip 30-40	Collier élastique
6	GS120SPEC	Manicotto aspirazione	Inlet hose	Durite d'aspiration
7	DP1	Dado 1"	Nut 1"	Ecrou plastique
8	OR3131	Or 3131	O-ring 3131	Joint torique
9	GAPS1299B	Piletta aspirazione pompa scarico	Drain boss	Bonde d'aspiration pompe de vidange
10	GAGS1299	Astina filtro	Filter spindle	Tige de filtre
11	GA013B	Nottolino filtro	Filter retaining nut	Ecrou de filtre
12	GAFAPS199	Filtro aspirazione pompa scarico	Drain pump filter	Filtre pompe de vidange
13	CEPSVSF	Valvola non ritorno scarico	Drain non return valve	Valve non retour, vidange
14	FAM710	Fascetta a molla	Spring clip	Collier
15	TSIL48	Tubo silicone	Silicone tube	Tuyau silicone
16	GSDETPI10COMP	Portagomma inox completo	Conn'n elbow, steel, complete assy	Support inox complete
17	GSTS2500PS	Tubo scarico l.2500 mm	External drain outlet hose	Tuyau de vidange l,250 mm

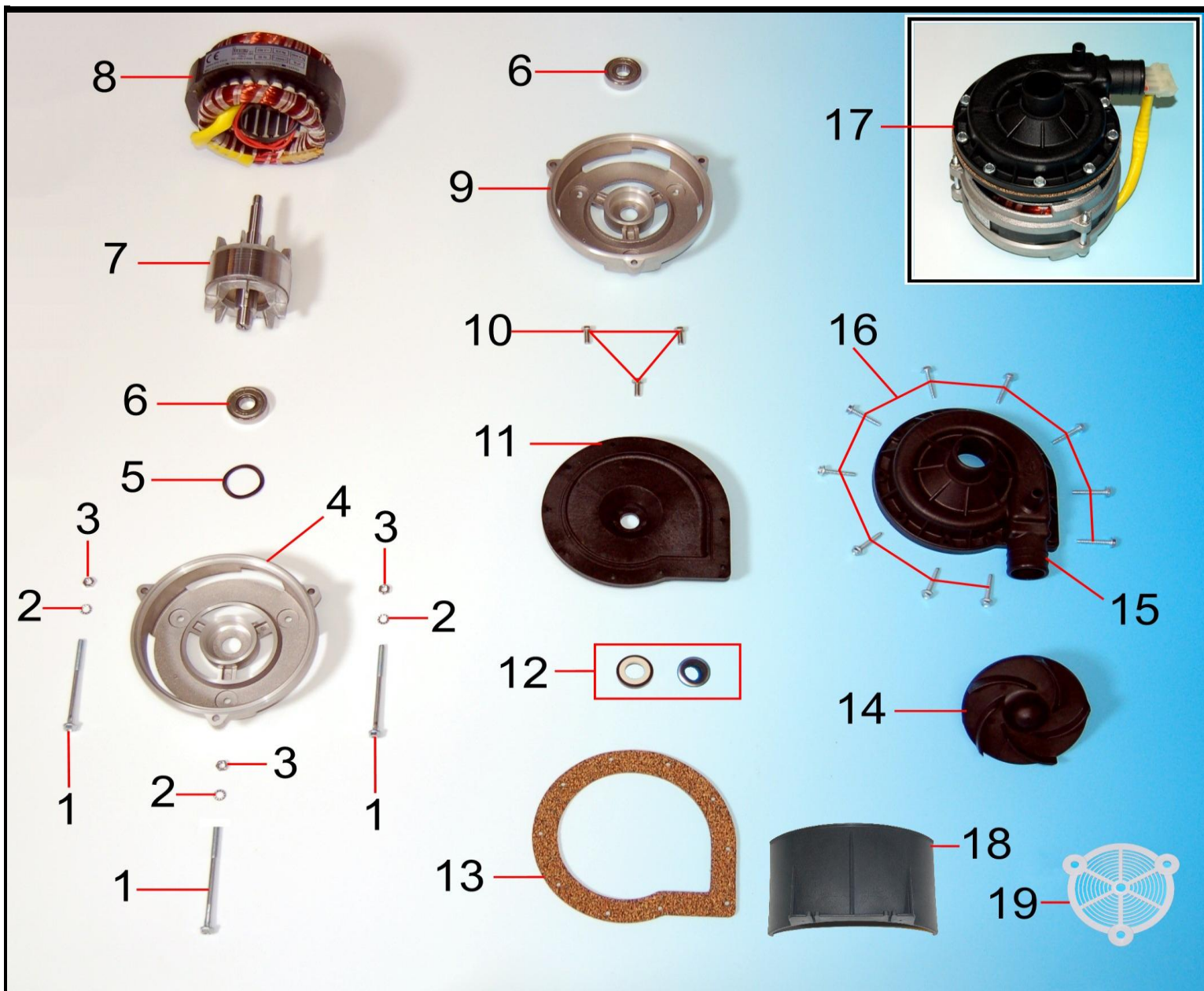

Pos.	Codice	Descrizione	Description	Description
1	VVTE560Z	Vite TE 5x60	Special screw	Vis
2	VR5I	Rondella dentata diametro 5	Special washer	Rondelle éventillé, diam. 5
3	VD5I	Dado esagonale m 5	Special nut	Ecrou M5
4	EP05M5	Calotta alluminio (filettata)	Endplate NDE	Calotte aluminium pompe
5	EP011	Anello compensazione pompa	Bearing ring	Boucle compensation pompe
6	EP07	Cuscinetto per motore pompa	Bearing	Roulement pour moteur pompe
7	EP2589	Rotore con albero	Rotor, 0.3HP	Rotor de compression
8	EP2510	Statore avvolto	Stator, 0.3HP	Stator pompe
9	EP05	Calotta alluminio	Endplate DE	Calotte aluminium pompe
10	VVTE512I	Vite TE 5x12	Special screw	Vis mm 5x12
11	EP255TP	Fondo pompa piccola	Impellor back plate	Fond pompe
12	EP04	Anello tenuta	Rotating seal	Boucle pompe
13	EP252NT	Guarnizione pompa	Cork gasket 0.3HP	Joint pompe
14	EP253	Girante pompa piccola	Impellor, diam. 88 mm	Turbine de pompe, diam. 88mm
15	EP251TP	Corpo pompa piccola	Impellor housing	Corps pompe
16	VATE4225Z	Vite autofilettante 4,2x25	Special screw	Vis 4,2x25
17	EP30	Elettropompa 0,3 hp 230v 50hz	Wash pump complete, 0.3 HP	Pompe de lavage
18	GLPPH25PL	Protezione pompa	Pump protection	Protection pompe
19	AM0GVP	Griglia ventilazione pompa	Pump ventilation grill	Grille protection pompe

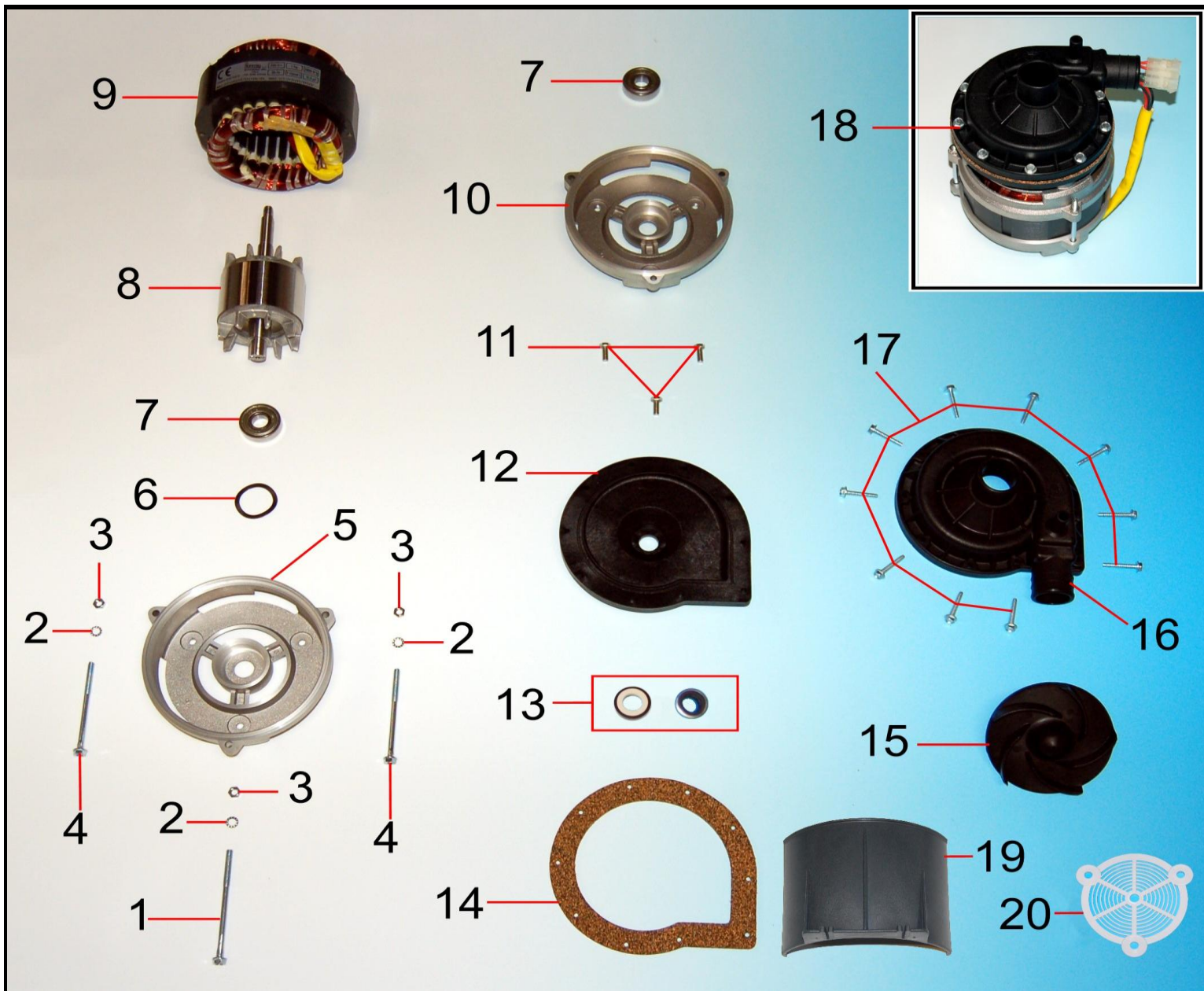

Pos.	Codice	Descrizione	Description	Description
1	VVTE580Z	Vite TE 5x80	Special screw	Vis
2	VR5I	Rondella dentata diametro 5	Special washer	Rondelle éventailé diam 5
3	VD5I	Dado esagonale m 5	Special nut	Ecrou M5
4	VVTE570Z	Vite TE 5x70	Special screw	Vis
5	EP05M5	Calotta alluminio (filettata)	Endplate NDE	Calotte aluminium pompe
6	EP011	Anello compensazione pompa	Bearing seal	Boucle compensation pompe
7	EP07	Cuscinetto per motore pompa	Bearing	Roulement pour moteur pompe
8	EP5089	Rotore con albero	Rotor 0.6HP	Rotor de compression
9	EP7510	Statore avvolto	Stator 0.6HP	Stator pompe
10	EP05	Calotta alluminio	Endplate DE	Calotte aluminium pompe
11	VVTE512I	Vite TE 5x12	Special screw	Vis m 5x12
12	EP255TP	Fondo pompa piccola	Impellor back plate	Fond pompe
13	EP04	Anello tenuta	Rotating seal	Boucle pompe
14	EP252NT	Guarnizione pompa	Cork gasket 0.6HP	Joint pompe
15	EP253	Girante pompa piccola	Impellor	Turbine de pompe, diam 88 mm
16	EP251TP	Corpo pompa piccola	Impellor housing	Corp pompe
17	VATE4225Z	Vite autofilettante 4,2x25	Special screw	Vis 4,2x25
18	EP60	Elettropompa 0,6 hp 230v 50hz	Wash pump complete 0.6HP	Pompe de lavage
19	GLPPH40PL	Protezione pompa	Pump protection	Protection pompe
20	AM0GVP	Griglia ventilazione pompa	Pump ventilation grill	Grille protection pompe

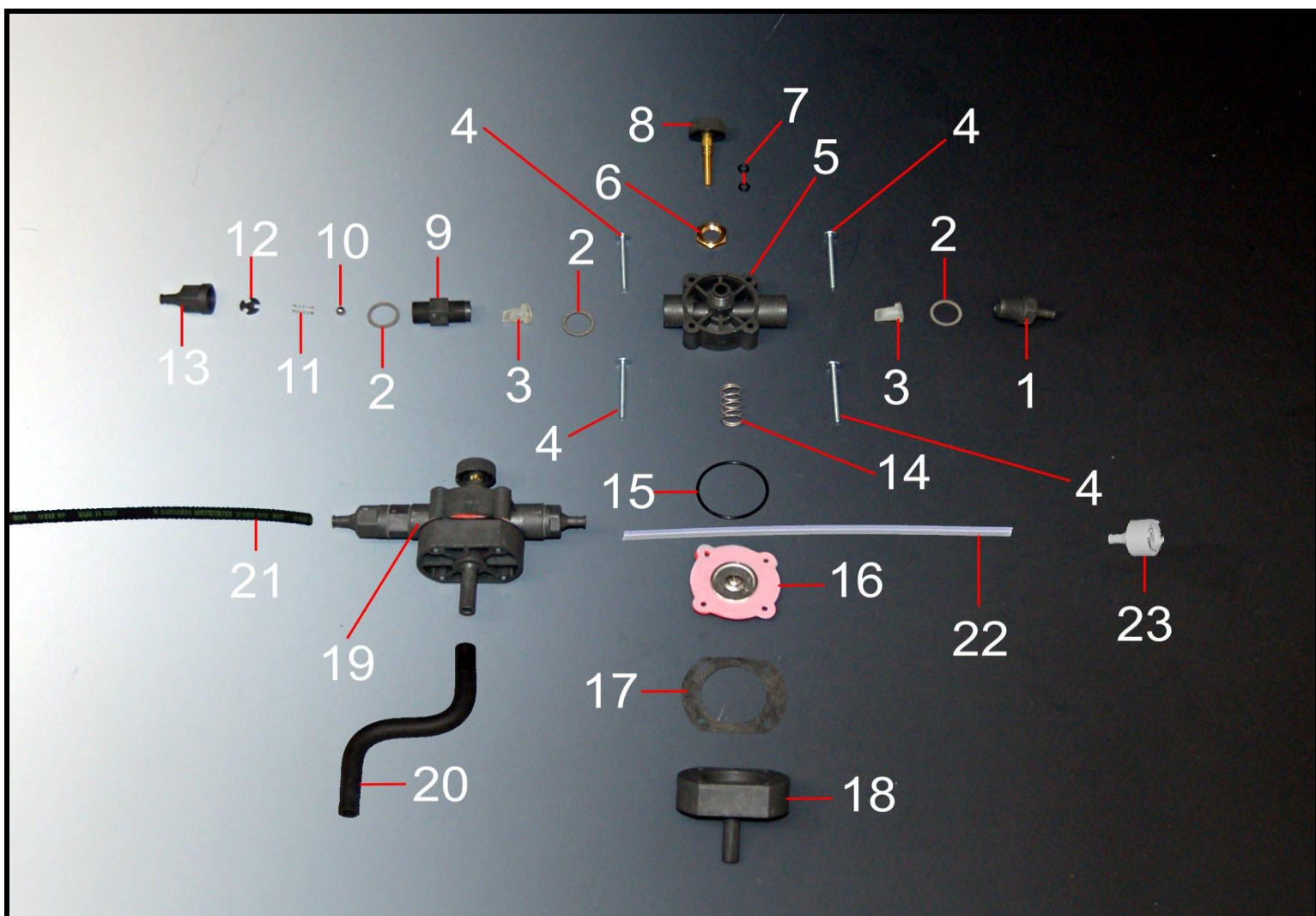

Pos.	Codice	Descrizione	Description	Description
1	DS10NT	Raccordo stringitubo	Inlet nipple	Raccord
2	G16221F	Guarnizione fibra 17x22x1,5	Seal for injector	Joint pour injecteur
3	DS8S	Valvolina silicone	Non return valve, rubber	Soupape en silicone
4	VVTCC445Z	Vite fissaggio	Special screw	Vis serrage
5	DS3	Corpo dosatore	Injector front body	Corps doseur produit de rinçage
6	DS24	Dado 20x4x14	Brass nut 20x4x14	Ecrou 20x4x14
7	OR103	Or 103	O ring 103	Or 103
8	DS1	Volantino dosatore	Adjusting screw	Manette pour doseur
9	DSVNR12	Raccordo valvola non ritorno	Housing for non return valve	Raccord soupape
10	DSVNR13	Sfera 1/4"	1/4" Ball for non return valve	Bille 1/4"
11	DSVNR14	Molla valvola non ritorno	Spring for non return valve	Ressort clapet anti retour
12	DSVNR16	Dischetto valvola non ritorno	Special disk for non return valve	Petit disque clapet anti retour
13	DSVNR17NT	Raccordo stringitubo valvola non ritorno	Outlet nipple	Raccord clapet anti retour
14	DS4	Molla membrana	Spring for diaphragm	Ressort pour membrane
15	OR422	Or 42x2	O ring 42x2	Or 42x2
16	DS06M3	Membrana completa	Diaphragm	Membrane
17	DS15	Guarnizione 64x50x1	Seal 64x50x1 for diaphragm	Joint 64x50x1
18	DS15A	Supporto posteriore	Injector rear body	Support postérieur
19	DSAM3NT	Dosatore brillantante completo assemblato	Rinse aid injector, complete	Doseur produit de rinçage
20	DS227	Tubo dosatore pompa piccola	Injector operating hose, small	Tube, doseur , petite pompe
21	TG510DS	Tubo dosatore 5x10	Rinse aid tube to boiler	Tube doseur 5x10
22	TSIL48	Tubo silicone 4x8	Silicone rinse aid inlet tube	Tube silicone 4x8
23	D0SVFFC	Valvola di fondo con filtro	Foot valve with filter	Clapet avec filtre

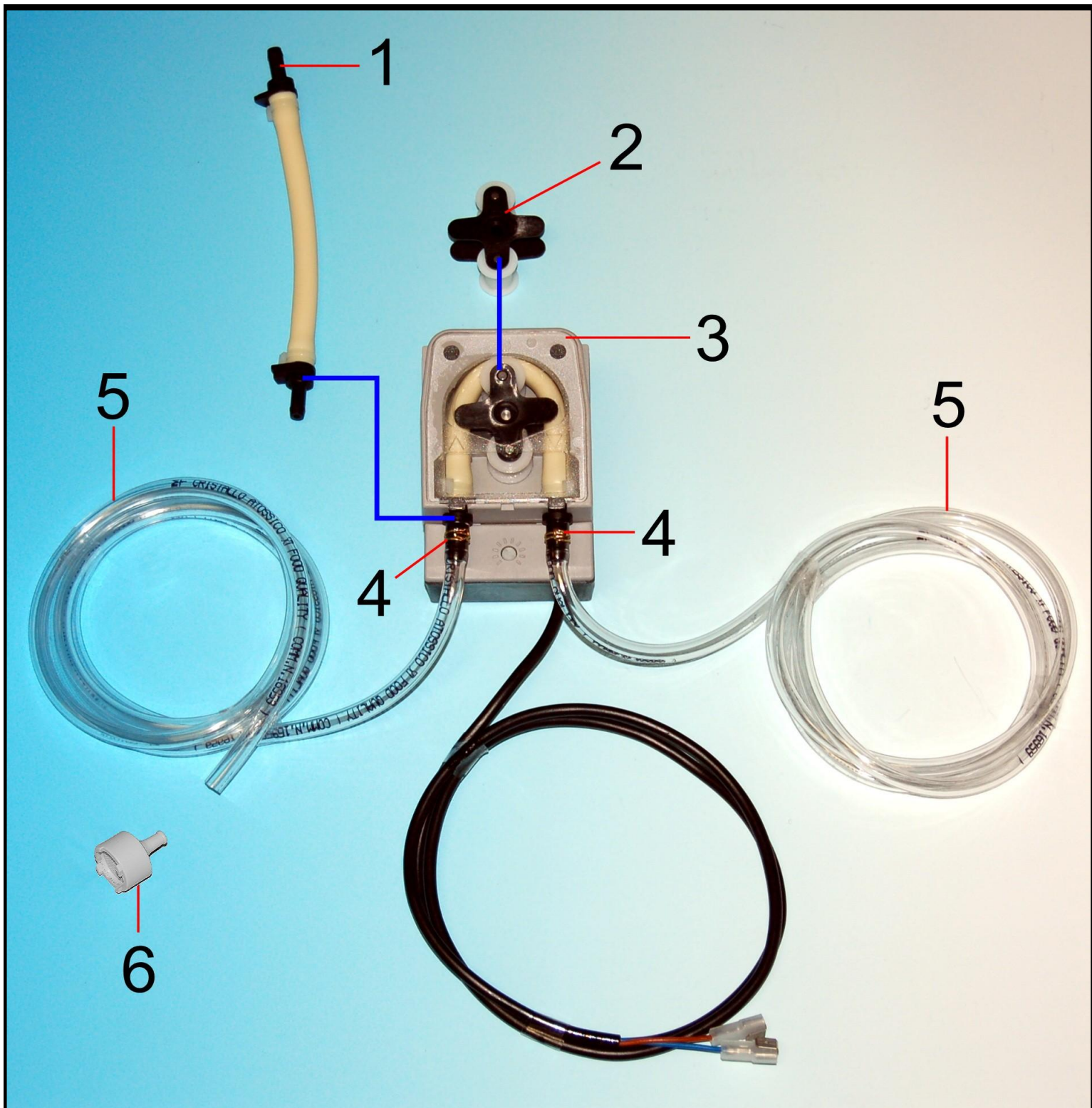

Pos.	Codice	Descrizione	Description	Description
1	D0STSANSKC	Tubo Santoprene detergente+attacchi	Peristaltic soap tube with fittings	Tube Santoprene doseur p. lavage
2	D0SPRRSKC	Portarullini peristaltica seko	Rotating pump head, soap	Rotor
3	D0SDETETLE	Dosatore detergente "eur"	Soap pump	Doseur produit de lavage "eur"
4	FAM710	Fascetta a molla	Spring clip for tubing	Collier
5	TC58	Tubo pvc cristal 5x8	Soap PVC tubing	Tube pvc cristal 5x8
6	D0SVFFC	Valvola di fondo con filtro	Foot valve with filter	Clapet avec filtre

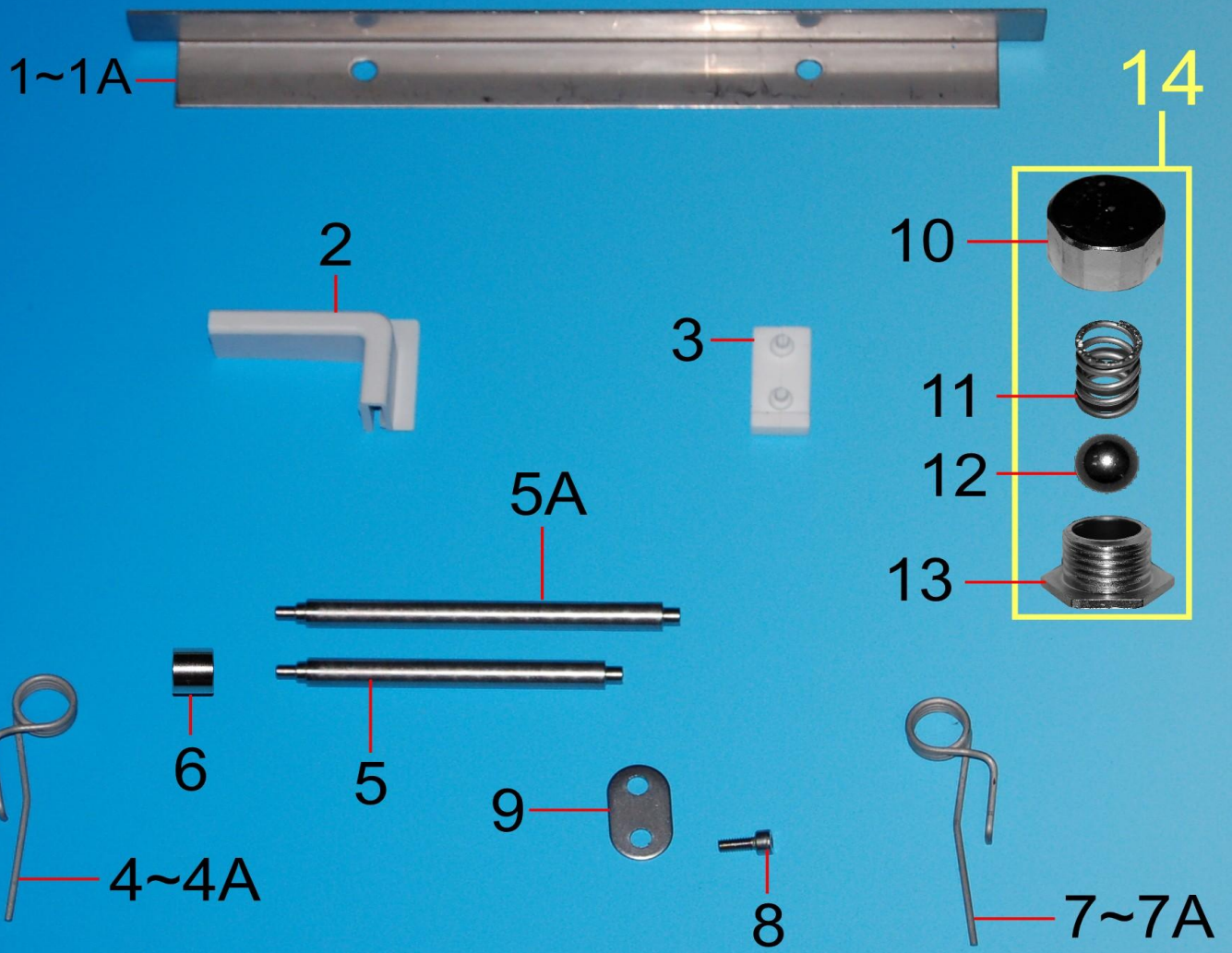

Pos.	Codice	Descrizione	Description	Description
1	GMDP1	Deflettore porta 35	Door deflector	Deflecteur porte
1A	GMDP2	Deflettore porta 40	Door deflector	Deflecteur porte
2	AM014B	Angolare vasca plastica	Plastic corner guard	Coin extérieure, plastique
3	AMPCP	Paracolpo porta	Door stop	Pare-chocs
4	AMMP1DX	Molla destra per porta 35	Door spring, RH	Ressort droit porte
4A	AMMP1A2DX	Molla destra per porta 40	Door spring, RH	Ressort droit porte, porte haute
5	AM112NTM	Perno porta 35	Door pin	Axe de la porte
5A	AM212NTM	Perno porta 40	Door pin	Axe de la porte
6	AM012M	Distanziale	Door pin spacer	Entretoise
7	AMMP1SX	Molla sinistra per porta 35	Door spring, LH	Ressort gauche porte
7A	AMMP1A2SX	Molla sinistra per porta 40	Door spring, LH	Ressort gauche porte, porte haute
8	VVEI410I	Vite, 4x10 mm	Screw, 4x10 mm	Vis, 4x10 mm
9	AM0PFPPM	Piastrina fissaggio perno porta	Pin security plate	Plaquette tenue pivot porte
10	AM011A	Dado scrocchetto vasca	Ball catch nut	Bouchon de la bille
11	AM011C	Molla scrocchetto	Ball catch spring	Ressort inox
12	AM011D	Sfera scrocchetto	Ball catch ball	Bille inox
13	AM011E	Sede sfera scrocchetto	Ball catch seat	Siège ressort inox
14	AM011	Scrocchetto completo vasca	Door ball catch assy	Fermeture de porte

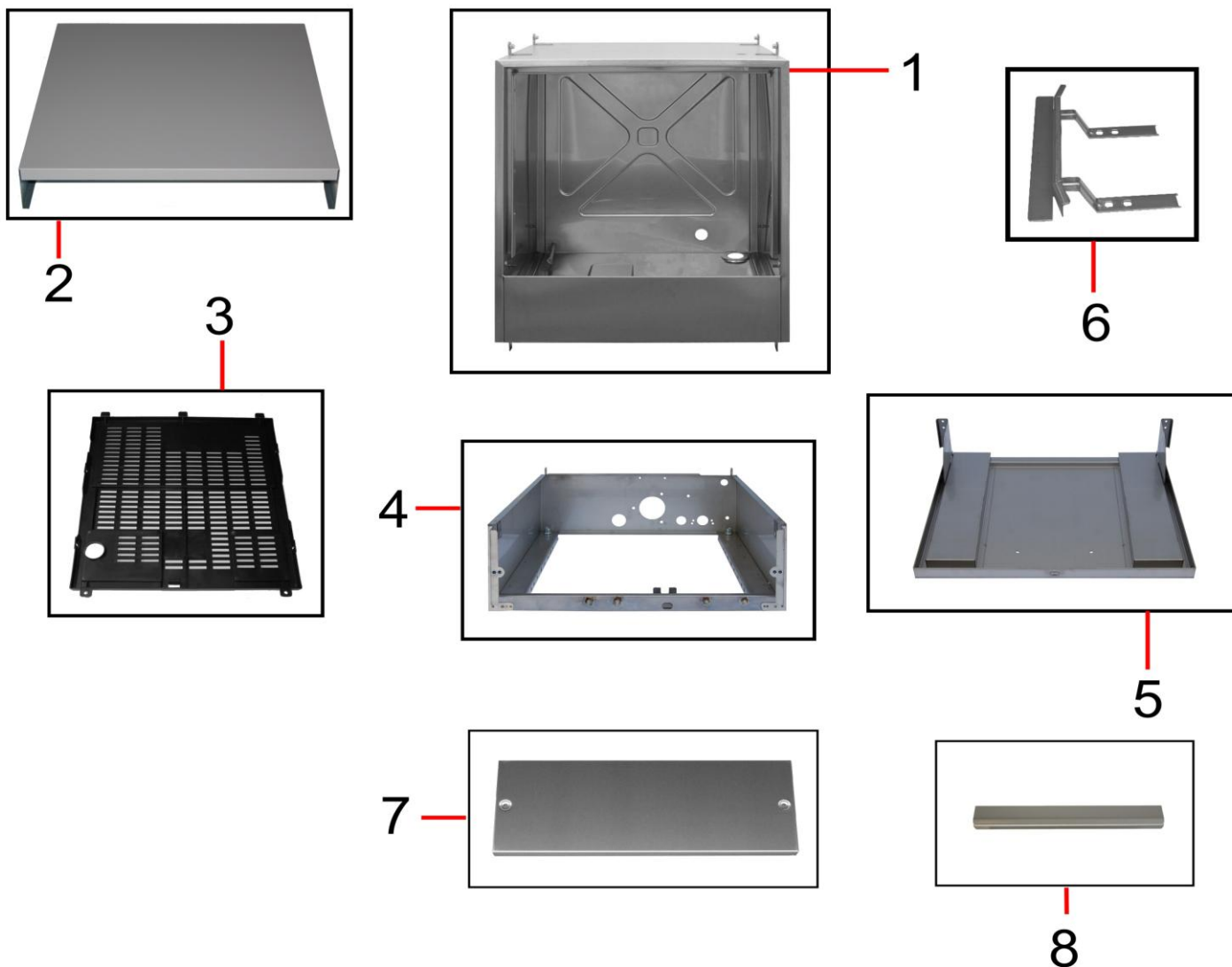

Pos.	Codice	Descrizione	Description	Description
1	GMVA1CS	Vasca	Wash cabinet	Cuve
2	GMPP1H65	Pannello posteriore	Back panel	Panneau dossieret
3	GMBAPR1PL	Protezione fondo basamento	Base protection screen	Protection panneau inferieur
4	GMBA1	Basamento	Base	Socle
5	GMP01M	Porta	Door	Porte
6	GMGCSF1DSXI	Guida dx-sx supporto cestello	Basket ramp, RH/LH	Support panier gauche/droit
7	GMCR1SC	Cruscotto inox senza cava	Bottom panel, steel	Panneau socle inox,
8	AM010R	Maniglia poligonale inox	Handle, Stainless steel, angled section	Poignée porte inox inclinée



3

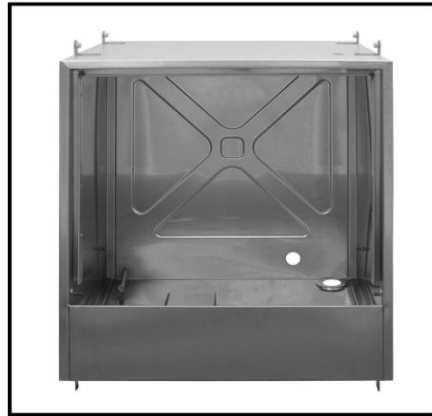

2



1

4

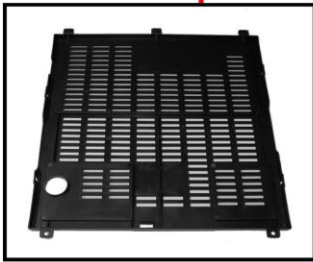

5



7

8

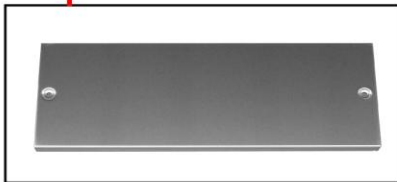

6



9



Pos.	Codice	Descrizione	Description	Description
1	GMPSPP6508	Pannello superiore	Top panel, steel	Panneau supérieur inox
2	GMVA2APR5	Vasca	Wash cabinet	Cuve carrée
3	GMPP2APR5	Pannello posteriore	Back panel	Panneau dossier
4	GMBAPR2PL	Protezione fondo basamento	Base protection screen	Protection panneau inférieur
5	GMBA2APR5	Basamento	Base	Socle
6	GMP02AMPR5	Porta	Door	Porte
7	GMGC2DSXI	Guida supporto cestello	Basket ramp, RH/LH	Support panier gauche/droit
8	GMCR2SC	Cruscotto inox senza cava	Bottom panel, steel	Panneau socle inox,
9	AM010R	Maniglia poligonale inox	Handle, Stainless steel, angled section	Poignée porte inox inclinée

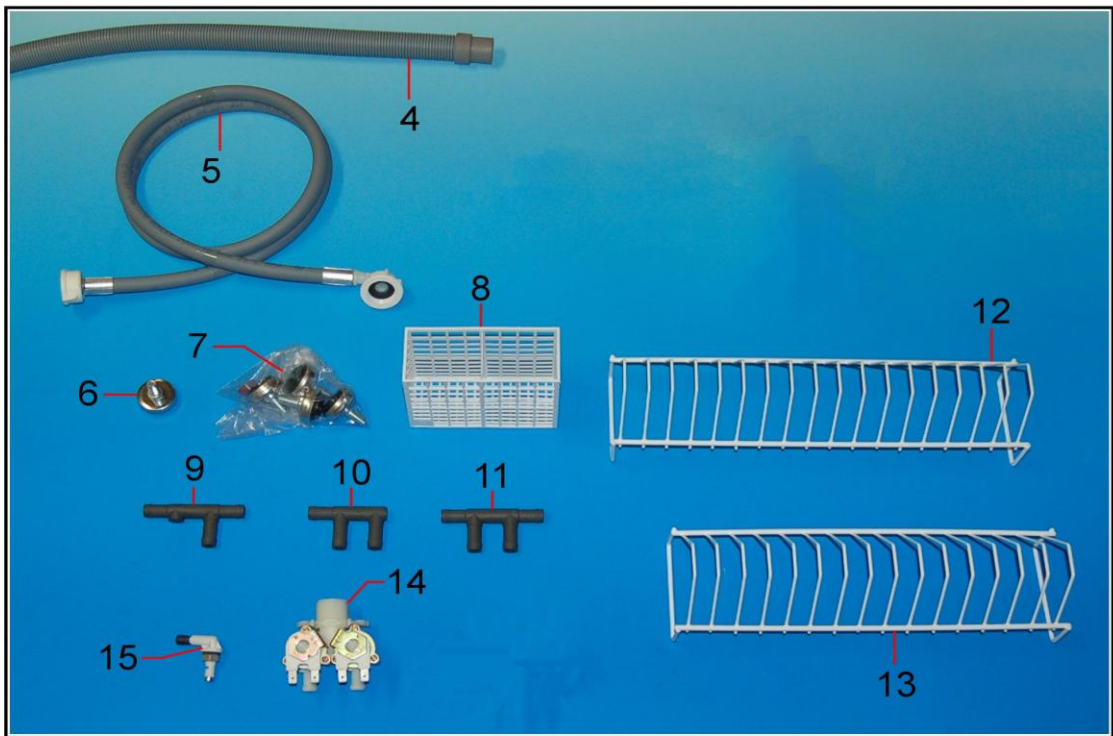
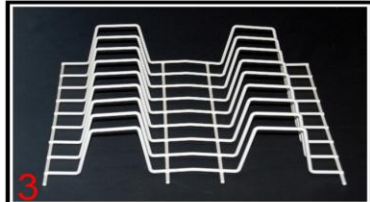

Pos.	Codice	Descrizione	Description	Description
1	CQ3516LPL	Cestello 35x35x16	Glass basket 35cm square plastic	Panier 35x35x16
2	CQ4016LPL	Cestello 40x40x16	Glass basket 40cm square plastic	Panier 40x40x16
3	CQIP408P	Inserto piatti 8 posti 40x40	Dish insert 400 square 8 plates	Support 8 assiettes 40x40
4	GS130	Tubo scarico Ø 25	Drain Pipe Diam 25	Tuyau de vidange, diam 25
5	TC3415	Tubo carico "vde" mt. 1,5	Water Supply Hose, 3/4" BSP, 1,5 m	Tuyau entrée eau "vde" mt. 1,5
6	AM016NT	Piedino regolabile lavabicchieri	Adjustable foot - glasswashers	Pied réglable - lave verres
7	AM016NTC	Confezione 4 piedini lavabicchieri	Set of 4 adjustable feet - glasswashers	Set nr.4 pieds - laveverres
8	IP2PP	Inserto porta posate piccolo	Small cutlery basket	Godet porte couverts petit
9	GB017	Portagomma a "T" 1 via	Tee Connector	Raccord à "T" 1 voie
10	GB017NT	Portagomma a "L" 1 via	3 Way Connector	Raccord à "L" 1 voie
11	GB055	Portagomma a "T" 2 vie	Double Tee Connector	Raccord à "T" 2 voies
12	CTIP17	Inserto porta piattini 17 posti	Large saucer rack	Godet porte soucoupes petit (17 assiettes)
13	CTIP15	Inserto porta piattini 15 posti	Small saucer rack	Godet porte soucoupes (15 assiettes)
14	CEEV2	Elettrovalvola 2 vie 220 volt	Solenoid Valve, 2-Way, 220V	Electrovanne 2 voies 220 volt
15	DSDET040BC	Iniettore completo	Soap Elbow Assy	Injecteur completo

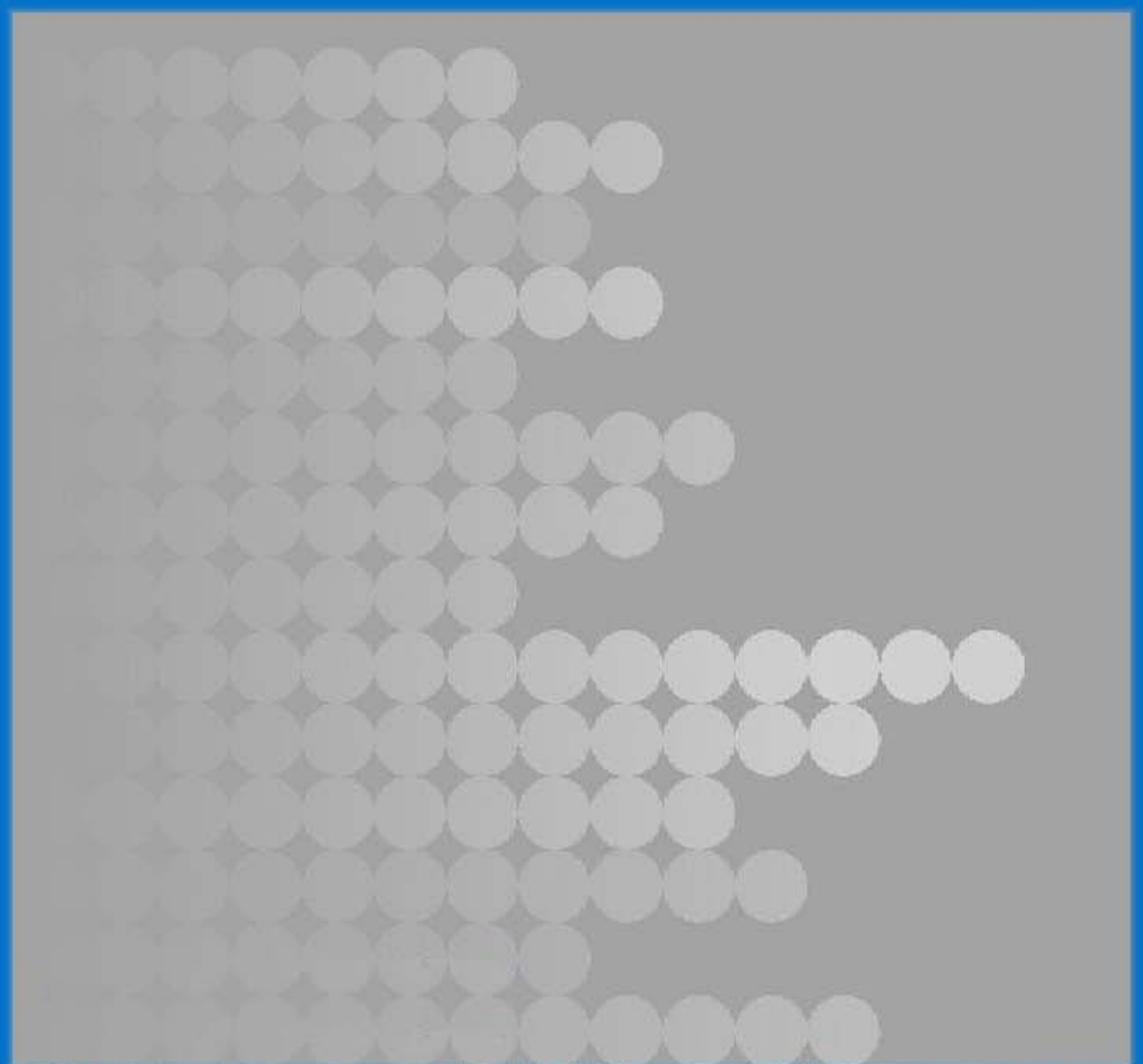

1009/1000.00 MASTER

